

Rockchip RK628 Datasheet

**Revision 1.0
June. 2020**

Revision History

Date	Revision	Description
2020-06-01	1.0	Initial released

Table of Content

Table of Content	3
Figure Index	4
Table Index.....	5
Warranty Disclaimer.....	6
Chapter 1 Introduction	7
1.1 Features	7
1.2 Block Diagram	9
Chapter 2 Package Information.....	10
2.1 Order Information	10
2.2 Top Marking	10
2.3 Package Information.....	10
2.4 WBBGA144 Dimension	10
2.5 WBBGA144 Pin Number Order.....	12
2.6 WBBGA144 Ball Map.....	13
2.7 Pin Description.....	14
2.8 RK628 Power/Ground IO Description	14
2.9 RK628 Function IO Description	15
2.10 IO Pin Name Description.....	17
2.11 RK628 IO Type.....	18
Chapter 3 Electrical Specification	20
3.1 Absolute Maximum Ratings.....	20
3.2 Recommended Operating Condition	20
3.3 DC Characteristics	20
3.4 Recommended Operating Frequency	21

Figure Index

Fig. 1-1 RK628 Block Diagram	9
Fig.2-1 Package definition	10
Fig. 2-2 RK628 WBBGA144 Package Top View and bottom View.....	10
Fig. 2-3 RK628 WBBGA144 Package side View	11
Fig. 2-4 RK628 WBBGA144 Package side View	11
Fig. 2-5 RK628 WBBGA144 Package Dimension.....	11
Fig. 2-6 RK628 BGA144 Ball Map	14

Table Index

Table 1-1 RK628 video input interface	7
Table 1-2 RK628 video output interface.....	8
Table 2-1 RK628 WBBGA144 Pin Number Order Information	12
Table 2-2 RK628 Power/Ground IO Information for BGA628	14
Table 2-3 RK628 Function IO Description	15
Table 2-4 RK628 IO Function Description List.....	17
Table 2-5 RK628 IO Type List	18
Table 3-1 RK628 Absolute Maximum Ratings	20
Table 3-2 RK628 Recommended Operating Condition	20
Table 3-3 RK628 DC Characteristics.....	21
Table 3-4 RK628 Recommended Operating Frequency	21

Warranty Disclaimer

Rockchip Electronics Co., Ltd makes no warranty, representation or guarantee (expressed, implied, statutory, or otherwise) by or with respect to anything in this document, and shall not be liable for any implied warranties of non-infringement, merchantability or fitness for a particular purpose or for any indirect, special or consequential damages.

Information furnished is believed to be accurate and reliable. However, Rockchip Electronics Co., Ltd assumes no responsibility for the consequences of use of such information or for any infringement of patents or other rights of third parties that may result from its use.

Rockchip Electronics Co., Ltd.'s products are not designed, intended, or authorized for using as components in systems intended for surgical implant into the body, or other applications intended to support or sustain life, or for any other application in which the failure of the Rockchip Electronics Co., Ltd.'s product could create a situation where personal injury or death may occur, should buyer purchase or use Rockchip Electronics Co., Ltd.'s products for any such unintended or unauthorized application, buyers shall indemnify and hold Rockchip Electronics Co., Ltd and its officers, employees, subsidiaries, affiliates, and distributors harmless against all claims, costs, damages, expenses, and reasonable attorney fees arising out of, either directly or indirectly, any claim of personal injury or death that may be associated with such unintended or unauthorized use, even if such claim alleges that Rockchip Electronics Co., Ltd was negligent regarding the design or manufacture of the part.

Copyright and Patent Right

Information in this document is provided solely to enable system and software implementers to use Rockchip Electronics Co., Ltd 's products. There are no expressed or implied copyright licenses granted hereunder to design or fabricate any integrated circuits or integrated circuits based on the information in this document.

Rockchip Electronics Co., Ltd does not convey any license under its patent rights nor the rights of others.

All copyright and patent rights referenced in this document belong to their respective owners and shall be subject to corresponding copyright and patent licensing requirements.

Trademarks

Rockchip and Rockchip™ logo and the name of Rockchip Electronics Co., Ltd.'s products are trademarks of Rockchip Electronics Co., Ltd. and are exclusively owned by Rockchip Electronics Co., Ltd. References to other companies and their products use trademarks owned by the respective companies and are for reference purpose only.

Confidentiality

The information contained herein (including any attachments) is confidential. The recipient hereby acknowledges the confidentiality of this document, and except for the specific purpose, this document shall not be disclosed to any third party.

Reverse engineering or disassembly is prohibited.

ROCKCHIP ELECTRONICS CO., LTD. RESERVES THE RIGHT TO MAKE CHANGES IN ITS PRODUCTS OR PRODUCT SPECIFICATIONS WITH THE INTENT TO IMPROVE FUNCTION OR DESIGN AT ANY TIME AND WITHOUT NOTICE AND IS NOT REQUIRED TO UNDATE THIS DOCUMENTATION TO REFLECT SUCH CHANGES.

Copyright © 2020 Rockchip Electronics Co., Ltd.

All rights reserved. No part of this publication may be reproduced, stored in a retrieval system, or transmitted in any form or by any means, electric or mechanical, by photocopying, recording, or otherwise, without the prior written consent of Rockchip Electronics Co., Ltd.

Chapter 1 Introduction

RK628 is a high-integration interface chip, which can support HDMI /parallel RGB /BT1120 as input and dual MIPI/dual LVDS/GVI(general video interface)/parallel RGB/ BT1120 as output with featured scaler inside. The key application scenario is extension of display output port for original application processor such as RK3288 /RK3399, or HDMI in interface providing.

1.1 Features

The features listed below which may or may not be present in actual product, may be subject to the third party licensing requirements. Please contact Rockchip for actual product feature configurations and licensing requirements.

1.1.1 Video input interface

- HDMI interface
 - Compliant with HDMI 1.4/HDMI 2.0
 - Supports HDCP 1.4
 - Supports 8/10bit per component video format
 - Supports rgb/yuv444/yuv422/yuv420
 - Supports Max resolution 4k@60fps
 - Supports data rates up to 600MHZ,with phy bit rate 6Gbps per lane
 - Supports DDC Bus I2C master interface at 3.3/5V
 - Supports EDID and CEC function
- Parallel interface
 - Supports Max resolution 1080p@60fps
 - Supports 16bits BT1120 in
 - Supports 24bits parallel rgb in

Table 1-1 RK628 video input interface

Interface	Resolution	Data rate	Bit rate per lane
HDMI	4k@60fps	NA	6Gbps
BT1120	1080p@60fps	148.5M	NA
RGB	1080p@60fps	148.5M	NA

1.1.2 Video output interface

- HDMI interface
 - Supports all DTV resolutions including 480p /576p /720p /1080p
 - Supports data rate from 25MHz, 1.65bps up to 3.4Gbps over a Single channel HDMI Internal SRAM
 - TMDS Tx Drivers with programmable output swing, resister values and pre-emphasis
 - DDC Bus I2C master interface at 3.3/5V
 - The EDID and CEC function are also supported by HDMI Transmitter Controller
- MIPI interface
 - DSI
 - ◆ Compliant with MIPI DPHY V1.2
 - ◆ Support the DPI interface color coding mappings into 24-bit Interface
 - ◆ Up to 4 DPHY Data Lanes per channel
 - ◆ Supports data rate up to 1.2Gbps
 - ◆ Supports dual channel dsi
 - CSI
 - ◆ Compliant with MIPI DPHY V1.2
 - ◆ Support format :RAW8
 - ◆ Up to 4 DPHY Data Lanes
 - ◆ Supports data rate up to 1.2Gbps
 - ◆ Supports single channel
- GVI interface
 - Supports RGB666/RGB888/RGB101010/YCbCR422-8bit/YCBCR422-10bit format
 - Supports Max resolution 4k@60fps

- Supports up to 3.75Gbps data rate(effective data rate 3Gbps)
- Supports 1/2/4/8 lanes
- Supports output lanes flexible mapping
- Supports 1/2 section mode
- LVDS interface
 - Compliant with the Standard TIA/EIA-644-A LVDS standard
 - Supports data rate up to 1Gbps
 - Support 8bit format-1, format-2, format-3 display mode, Support 6bit display mode.
 - Supports dual channel lvds
- Parallel interface
 - Supports Max resolution 1080p@60fps
 - Supports 16bits BT1120 out
 - Supports 24bits parallel rgb out

Table 1-2 RK628 video output interface

Interface	Resolution	Data rate	Bit rate per lane
GVI	4k@60fps	NA	3.75Gbps
Dual MIPI	2k@60fps	NA	1.2Gbps
MIPI	1080p@60fps	NA	1.2Gbps
Dual LVDS	1080p@60fps	NA	1 Gbps
LVDS	720p@60fps	NA	1 Gbps
BT1120	1080p@60fps	148.5M	NA
RGB	1080p@60fps	148.5M	NA

1.1.3 TX/RX adapter

- Interaction of HDP signal between HDMI TX and HDMI RX
- Support HDMI TX CEC function
- Support RX HDCP1.3 inside-key memory. It is readable and writable
- Support HDMI RX/TX
- Support on-chip EDID memory. It is readable and writable

1.1.4 Post process

- CSC
 - RGB2YUV
 - YUV2RGB
 - YUV2VYU
- Display interface
 - Parallel display Interface: 30-bit(RGB/YUV)
 - Asynchronous output pixel clock (PLL required)
 - Flexible display timing setting
 - Configurable border black area
- Scaling down
 - Max input resolution: 4096x2160
 - Arbitrary non-integer scaling ratio
 - Support two mode: bilinear and average
 - Max 1/4 scaling ratio for bilinear scaling down
 - Max 1/6 scaling ratio for average scaling down
- Scaling up
 - Max output resolution: 4096x2160
 - Arbitrary non-integer scaling ratio
 - Support four scaling up mode for different effect
 - Max 6 scaling ratio
- Split
 - Left-right mode
 - Odd-even mode

1.1.5 Others

- Audio
 - Support hdmi RX I2S interface, up to 192kHz sample rate, 8 channel

- Support I/O I2S interface, 8 channel
- Support hdmi TX I2S interface, 8 channel
- Support the connection of RX and TX's I2S
- eFuse
 - One-time programmable nonvolatile EFUSE storage cells organized as 64x8 bits
 - 1.1V typical core voltage
 - AVDD is NOT allowed to exceed 2.75V
 - Burning requirements:
 - ◆ 2.5V typical burning voltage (AVDD), AVDD must be high during PGM mode. AVDD must be low or floating during READ mode and inactive mode
 - ◆ 2us burning pulse width
 - ◆ Ambient temperature range of 10~40°C
 - ◆ Burning at wafer, package, or field level
- Package Type
 - BGA144

1.2 Block Diagram

The following diagram shows the basic block diagram for RK628.

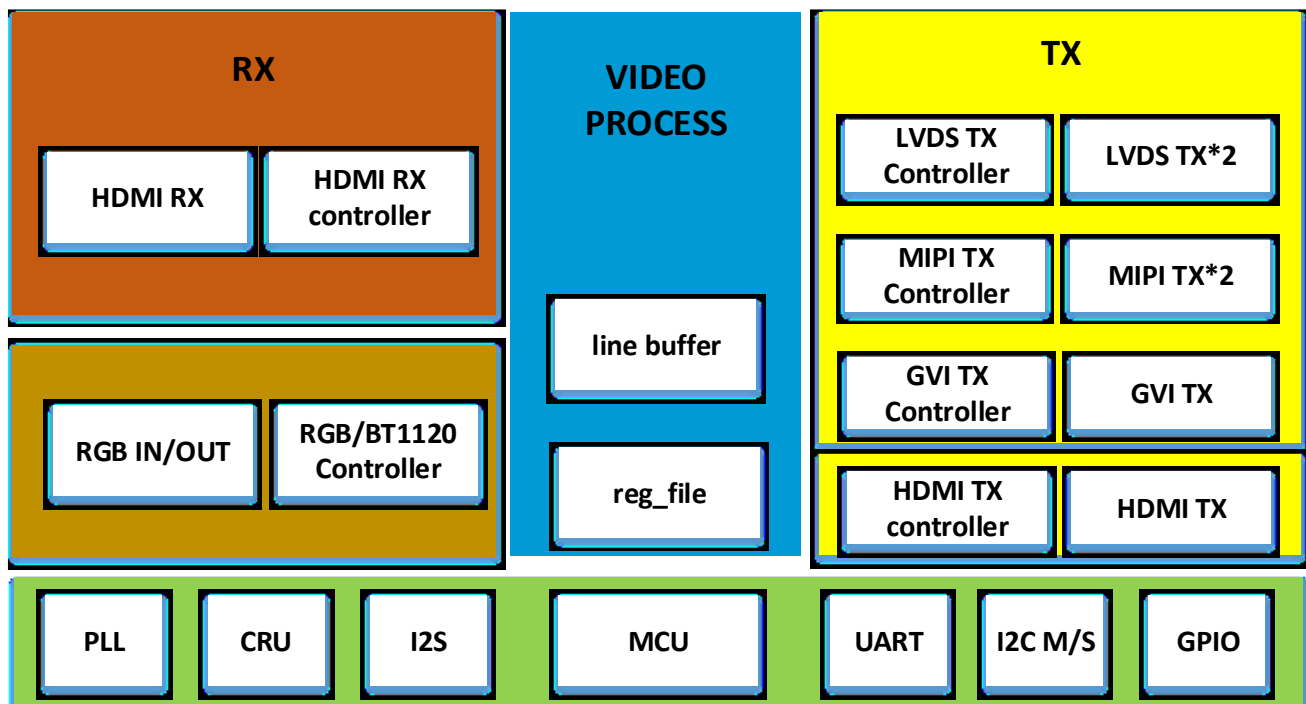

Fig. 1-1 RK628 Block Diagram

Chapter 2 Package Information

2.1 Order Information

Orderable Device	RoHS status	Package	Package Qty	Device Feature
RK628	RoHS	TFBGA144	TBD	High speed interface bridge chip

2.2 Top Marking

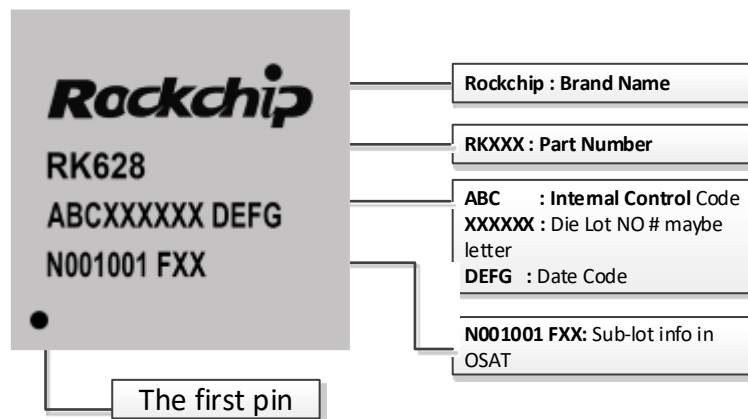

Fig.2-1 Package definition

2.3 Package Information

RK628 has the type of package:

BGA144(body: 8mmx8mm; ball size: 0.3mm; ball pitch: 0.65mm)

2.4 WBBGA144 Dimension

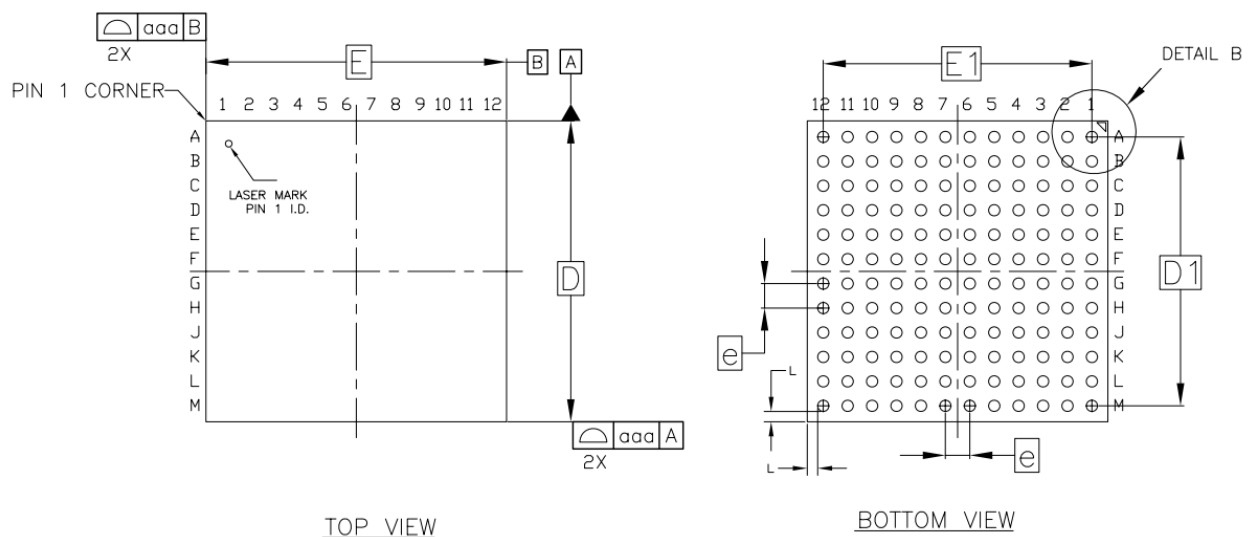

Fig. 2-2 RK628 WBBGA144 Package Top View and bottom View

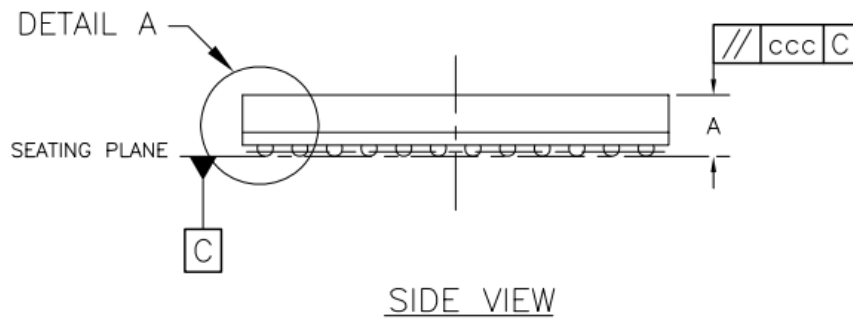

Fig. 2-3 RK628 WBBGA144 Package side View

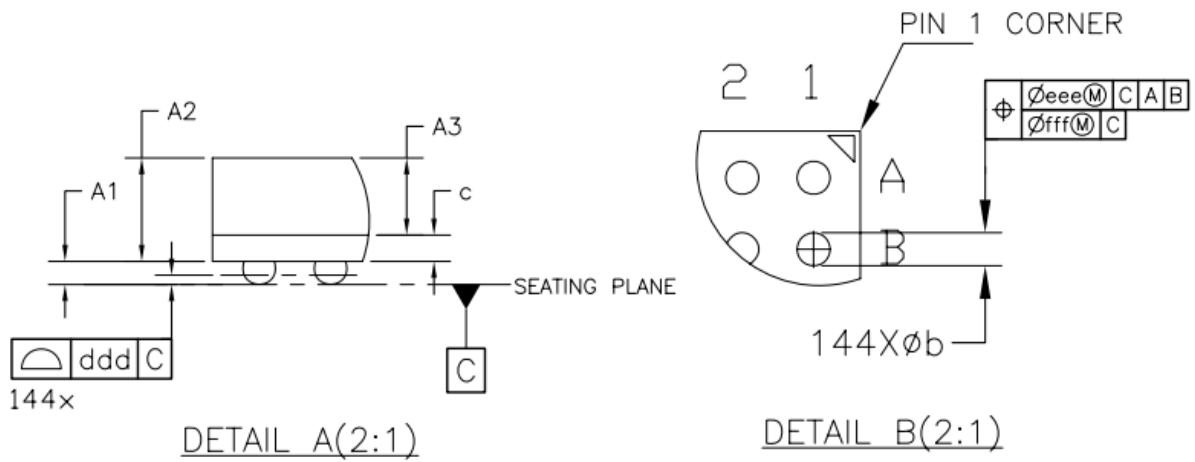

Fig. 2-4 RK628 WBBGA144 Package side View

SYMBOL	MILLIMETER		
	MIN	NOM	MAX
A	--	1.15	1.23
A1	0.16	0.21	0.26
A2	0.89	0.94	0.99
A3	0.70 BASIC		
c	0.20	0.24	0.28
D	7.90	8.00	8.10
D1	7.15 BASIC		
E	7.90	8.00	8.10
E1	7.15 BASIC		
e	0.65 BASIC		
b	0.25	0.30	0.35
L	0.275 REF		
aaa	0.15		
ccc	0.15		
ddd	0.10		
eee	0.15		
fff	0.08		

Fig. 2-5 RK628 WBBGA144 Package Dimension

Note:

1. CONTROLLING DIMENSION: MILLIMETER.

2. PRIMARY DATUM C AND SEATING PLANE ARE DEFINED BY THE SPHERICAL CROWNS OF THE SOLDER BALLS.
3. DIMENSION *b* IS MEASURED AT THE MAXIMUM SOLDER BALL DIAMETER, PARALLEL TO PRIMARY DATUM C.
4. SPECIAL CHARACTERISTICS C CLASS: A, *ddd*.
5. THE PATTERN OF PIN 1 FIDUCIAL IS FOR REFERENCE ONLY.
6. THE TILT OF HEAT SINK SHOULD BE WITHIN 10MIL(0.254mm) (VERTICAL POSITION).

2.5 WBBGA144 Pin Number Order

Table 2-1 RK628 WBBGA144 Pin Number Order Information

Pin Number	Pin Name	Pin Number	Pin Name
A1	VSS_1	G1	GVI/LVDS/MIPI_TX0N
A2	GVI/LVDS/MIPI_TX5P	G2	GVI/LVDS/MIPI_TX0P
A3	GVI/LVDS/MIPI_TX6P	G3	VSS_25
A4	GVI/LVDS/MIPI_TX7P	G4	VSS_19
A5	GVI/LVDS/MIPI_TX8P	G5	VSS_9
A6	GVI/LVDS/MIPI_TX9P	G6	VSS_13
A7	GPIO3_B1/GVI_HPD	G7	VSS_16
A8	GPIO3_A1/VOP_HSYNC	G8	VSS_20
A9	VOP_DCLK	G9	HDMIRX_EXTR
A10	GPIO2_C4/VOP_D20/JTAGTDI	G10	GPIO2_A0/VOP_D0
A11	GPIO2_C1/VOP_D17/XIPSFCSISO	G11	GPIO2_A1/VOP_D1
A12	VSS_2	G12	GPIO2_A2/VOP_D2
B1	GVI/LVDS/MIPI_REXT	H1	GPIO0_A7/I2S_D3_M0/UARTTRSTN
B2	GVI/LVDS/MIPI_TX5N	H2	GPIO0_A6/I2S_D2_M0/UARTCTSN
B3	GVI/LVDS/MIPI_TX6N	H3	GPIO0_A5/I2S_D1_M0/UARTRX
B4	GVI/LVDS/MIPI_TX7N	H4	RESETN
B5	GVI/LVDS/MIPI_TX8N	H5	VCCIO1
B6	GVI/LVDS/MIPI_TX9N	H6	VSS_29
B7	GPIO3_B2/GVI_LOCK	H7	GPIO1_A0/TEST_CLKO
B8	GPIO3_A3/VOP_VSYNC	H8	GPIO1_A1/SFC_CSLK
B9	GPIO3_A0/VOP_DEN	H9	HDMIRX_DVDD_1V1_1
B10	GPIO2_C3/VOP_D19/JTAGTDO	H10	VSS_18
B11	GPIO2_C0/VOP_D16/XIPSFCCSN	H11	HDMIRX_D2N
B12	GPIO2_B7/VOP_D15	H12	HDMIRX_D2P
C1	GVI/LVDS/MIPI_TX4N	J1	GPIO0_A3/I2S_LRCK_M0
C2	GVI/LVDS/MIPI_TX4P	J2	GPIO0_A2/I2S_SCK_M0
C3	GVI/LVDS/MIPI_PLL_AVDD_3V3	J3	INT/SPIBOOT
C4	VSS_26	J4	HDMITX_DVDD_1V1_2
C5	GVI/LVDS/MIPI_AVDD_1V1_3	J5	HDMITX_DVDD_1V1_3
C6	VSS_27	J6	HDMITX_DVDD_1V1_1
C7	I2C_ADDR	J7	PLL_AVDD_1V1
C8	GPIO2_C7/VOP_D23/JTAGTRSN	J8	EFUSE_VDD_2V5
C9	GPIO2_C6/VOP_D22/JTAGTCK	J9	HDMIRX_DVDD_1V1_2
C10	GPIO2_C2/VOP_D18/XIPSFCSOSI	J10	HDMIRX_AVDD_3V3_1
C11	GPIO2_B4/VOP_D12	J11	HDMIRX_D1N
C12	GPIO2_B6/VOP_D14	J12	HDMIRX_D1P
D1	GVI/LVDS/MIPI_TX3N	K1	GPIO0_B1/HDMITX_SDA
D2	GVI/LVDS/MIPI_TX3P	K2	GPIO0_A4/I2S_D0_M0/UARTTX
D3	VSS_5	K3	I2C_SDA
D4	GVI/LVDS/MIPI_AVDD_1V1_1	K4	HDMITX_AVDD_3V3
D5	GVI/LVDS/MIPI_AVDD_3V3_1	K5	VSS_7
D6	VSS_24	K6	VSS_22
D7	TEST	K7	VSS_10

Pin Number	Pin Name	Pin Number	Pin Name
D8	DVDD_2	K8	GPIO1_B0/HDMIRX_HPD_M0
D9	GPIO2_C5/VOP_D21/JTAGTMS	K9	GPIO1_B3/HDMIRX_CEC_M0
D10	GPIO2_B2/VOP_D10	K10	VSS_23
D11	GPIO2_B3/VOP_D11	K11	HDMIRX_D0N
D12	GPIO2_B5/VOP_D13	K12	HDMIRX_D0P
E1	GVI/LVDS/MIPI_TX2N	L1	GPIO0_B2/HDMITX_SCL
E2	GVI/LVDS/MIPI_TX2P	L2	GPIO0_B0/HDMITX_HPD
E3	GVI/LVDS/MIPI_AVDD_1V1_2	L3	I2C_SCL
E4	GVI/LVDS/MIPI_AVDD_3V3_2	L4	HDMITX_CLKN
E5	VSS_11	L5	HDMITX_D0N
E6	VSS_14	L6	HDMITX_D1N
E7	VSS_28	L7	HDMITX_D2N
E8	VCCIO2_1	L8	GPIO1_B2/HDMIRX_SCL_M0
E9	DVDD_1	L9	OSC_OUT
E10	GPIO2_A7/VOP_D7	L10	VSS_28
E11	GPIO2_B1/VOP_D9	L11	HDMIRX_CLKN
E12	GPIO2_B0/VOP_D8	L12	HDMIRX_CLKP
F1	GVI/LVDS/MIPI_TX1N	M1	VSS_4
F2	GVI/LVDS/MIPI_TX1P	M2	GPIO0_B3/HDMITX_CEC
F3	GVI/LVDS/MIPI_AVDD_1V1_4	M3	HDMITX_EXTR
F4	VSS_6	M4	HDMITX_CLKP
F5	VSS_8	M5	HDMITX_D0P
F6	VSS_12	M6	HDMITX_D1P
F7	VSS_15	M7	HDMITX_D2P
F8	VCCIO2_2	M8	GPIO1_B1/HDMIRX_SDA_M0
F9	GPIO2_A3/VOP_D3	M9	OSC_IN
F10	GPIO2_A6/VOP_D6	M10	PLL_AVDD
F11	GPIO2_A5/VOP_D5	M11	VSS_29
F12	GPIO2_A4/VOP_D4	M12	VSS_3

2.6 WBBGA144 Ball Map

144	1	2	3	4	5	6	7	8	9	10	11	12	
A	VSS_1	GVILVDSMPL_TX5_P	GVILVDSMPL_TX6_P	GVILVDSMPL_TX7_P	GVILVDSMPL_TX8_P	GVILVDSMPL_TX9_P	GPIO3_B1/GWL_HPD	GPIO3_A1/VOP_HS_YNC	VOP_DCLK	GPIO2_C4/VOP_D2_0/JTAGTDI	GPIO2_C1/VOP_D1_7/XIPSFCSISO	VSS_2	A
B	GVILVDSMPL_REXT	GVILVDSMPL_TX5_N	GVILVDSMPL_TX6_N	GVILVDSMPL_TX7_N	GVILVDSMPL_TX8_N	GVILVDSMPL_TX9_N	GPIO3_B2/GWL_LOC_K	GPIO3_A3/VOP_VS_YNC	GPIO3_A0/VOP_DE_N	GPIO2_C3/VOP_D1_9/JTAGTDO	GPIO2_C0/VOP_D1_8/XIPSFCCSN	GPIO2_B7/VOP_D1_5	B
C	GVILVDSMPL_TX4_N	GVILVDSMPL_TX4_P	GVILVDSMPL_PLL_AVDD_3V3	VSS_26	GVILVDSMPL_AVDD_1V1_3	VSS_27	I2C_ADDR	GPIO2_C7/VOP_D2_3/JTAGTRSN	GPIO2_C6/VOP_D2_2/JTAGTCK	GPIO2_C2/VOP_D1_8/XIPSFCSMO	GPIO2_B4/VOP_D1_2	GPIO2_B6/VOP_D1_4	C
D	GVILVDSMPL_TX3_N	GVILVDSMPL_TX3_P	VSS_5	GVILVDSMPL_AVDD_1V1_1	GVILVDSMPL_AVDD_3V3_1	VSS_24	TEST	DVDD_2	GPIO2_C5/VOP_D2_1/JTAGTMS	GPIO2_B2/VOP_D1_0	GPIO2_B3/VOP_D1_1	GPIO2_B5/VOP_D1_3	D
E	GVILVDSMPL_TX2_N	GVILVDSMPL_TX2_P	GVILVDSMPL_AVDD_1V1_2	GVILVDSMPL_AVDD_3V3_2	VSS_11	VSS_14	VSS_21	VCCIO2_1	DVDD_1	GPIO2_A7/VOP_D7	GPIO2_B1/VOP_D9	GPIO2_B0/VOP_D8	E
F	GVILVDSMPL_TX1_N	GVILVDSMPL_TX1_P	GVILVDSMPL_AVDD_1V1_4	VSS_6	VSS_8	VSS_12	VSS_15	VCCIO2_2	GPIO2_A3/VOP_D3	GPIO2_A6/VOP_D6	GPIO2_A5/VOP_D5	GPIO2_A4/VOP_D4	F
G	GVILVDSMPL_TX0_N	GVILVDSMPL_TX0_P	VSS_25	VSS_19	VSS_9	VSS_13	VSS_16	VSS_20	HDMIRX_EXTR	GPIO2_A0/VOP_D0	GPIO2_A1/VOP_D1	GPIO2_A2/VOP_D2	G
H	GPIO0_A7I2S_D3_M0/UARTTRSTN	GPIO0_A6I2S_D2_M0/UARTCTS	GPIO0_A5I2S_D1_M0/UARTTRX	RESETN	VCCIO1	VSS_17	GPIO1_A0/TEST_C_LKO	GPIO1_A1/SFC_CS_LK	HDMIRX_DVDD_1V1_1	VSS_18	HDMIRX_D2N	HDMIRX_D2P	H
J	GPIO0_A3I2S_LRC_K_M0	GPIO0_A2I2S_SCK_M0	INT/SPIBOOT	HDMITX_DVDD_1V1_2	HDMITX_DVDD_1V1_3	HDMITX_DVDD_1V1_1	PLL_AVDD_1V1	EFUSE_VDD_2V5	HDMIRX_DVDD_1V1_2	HDMIRX_AVDD_3V3_1	HDMIRX_D1N	HDMIRX_D1P	J
K	GPIO0_B1HDMITX_SDA	GPIO0_A4I2S_D0_M0/UARTTRX	I2C_SDA	HDMITX_AVDD_3V3	VSS_7	VSS_22	VSS_10	GPIO1_B0HDMIRX_HPD_M0	GPIO1_B3HDMIRX_CEC_M0	VSS_23	HDMIRX_D0N	HDMIRX_D0P	K
L	GPIO0_B2HDMITX_SCL	GPIO0_B0HDMITX_HPD	I2C_SCL	HDMITX_CLKN	HDMITX_D0N	HDMITX_D1N	HDMITX_D2N	GPIO1_B2HDMIRX_SCL_M0	OSC_OUT	VSS_28	HDMIRX_CLKN	HDMIRX_CLKP	L
M	VSS_4	GPIO0_B3HDMITX_CEC	HDMITX_EXTR	HDMITX_CLKP	HDMITX_D0P	HDMITX_D1P	HDMITX_D2P	GPIO1_B1HDMIRX_SDA_M0	OSC_IN	PLL_AVDD	VSS_29	VSS_3	M
	1	2	3	4	5	6	7	8	9	10	11	12	

Fig. 2-6 RK628 BGA144 Ball Map

2.7 Pin Description

In this chapter, the pin description will be divided into two parts, one is all power/ground descriptions in Table 2-2 for BGA144, include analog power/ground; another is all the function signals descriptions in Table 2-2, also include analog function signals.

2.8 RK628 Power/Ground IO Description

Table 2-2 RK628 Power/Ground IO Information for BGA628

Group	Ball#	Descriptions
VSS	A1,A12, C4,C6,D3,D6, E5,E6,E7, F4,F5,F6,F7, G3,G4,G5,G6,G7,G8 H6, H10, K5,K6,K7,K10, M1,M12,L10,M11	Ground
DVDD	D8,E9	Digital 1.1v power
VCCIO1	H5	IO1 3.3v power
VCCIO2	E8,F8	IO2 3.3v power
PLL_AVDD	M10	PII 3.3v power

Group	Ball#	Descriptions
PLL_AVDD_1V1	J7	PLL 1.1v power
EFUSE_VDD_2V5	J8	Effuse 2.5 power
GVI/LVDS/MIPI_PLL_AVDD_3V3	C3	TX PHY PLL Power
GVI/LVDS/MIPI_AVDD_3V3	D5,E4	TX PHY 3.3v Power
GVI/LVDS/MIPI_AVDD_1V1	C5,D4,E3,F3	TX PHY 1.1v Power
HDMITX_DVDD_1V1	J4,J5,J6	Hdmi tx digital 1.1v power
HDMITX_AVDD_3V3	K4	Hdmi tx analog 3.3v power
HDMIRX_DVDD_1V1	H9,J9	HDMI rx phy 1.1v power
HDMIRX_AVDD_3V3	J10	HDMI rx phy 3.3v power

2.9 RK628 Function IO Description

Table 2-3 RK628 Function IO Description

Pad#	Ball#	func1	func2	func3	Pad Type®	Drive Strength®	Pull	Reset State®	Power Supply
OSC_IN	M9				H	2	NA	I	
OSC_OUT	L9				H	2	NA	O	
RESETN	H4				B	2	Up	I	
TEST	D7				B	2	down	I	
I2C_ADDR	C7				B	4	down	I	
I2C_SCL	L3				G	4	up	I	
I2C_SDA	K3				G	4	up	I	
INT	J3				B	2	down	I	
GPIO0_A2/I2S_SCK_M0	J2	I2S_SCK_M0			D	12	down	I	
GPIO0_A3/I2S_LRCK_M0	J1	I2S_LRCK_M0			B	12	down	I	
GPIO0_A4/I2S_D0_M0/UA_RTX	K2	I2S_D0_M0			B	12	down	I	
GPIO0_A5/I2S_D1_M0/UA_RTRX	H3	I2S_D1_M0			B	12	down	I	
GPIO0_A6/I2S_D2_M0/UA_RTCTSN	H2	I2S_D2_M0			B	12	down	I	
GPIO0_A7/I2S_D3_M0/UA_RTRRSTN	H1	I2S_D3_M0			B	12	down	I	
GPIO0_B0/HDMITX_HPD	L2	HDMITX_HPD			E	4	down	I	
GPIO0_B1/HDMITX_SDA	K1	HDMITX_SDA			G	4	up	I	
GPIO0_B2/HDMITX_SCL	L1	HDMITX_SCL			G	4	up	I	
GPIO0_B3/HDMITX_CEC	M2	HDMITX_CEC			G	4	up	I	
GPIO1_A0/TEST_CLKO	H7	TEST_CLKO			B	4	down	I	
GPIO1_A1/SFC_CSLK	H8	SFC_CSLK			B	4	down	I	
GPIO1_B0/HDMIRX_HPD_M0	K8	HDMIRX_HPD_M0			F	4	up	I	
GPIO1_B1/HDMIRX_SDA_M0	M8	HDMIRX_SDA_M0			G	4	up	I	
GPIO1_B2/HDMIRX_SCL_M0	L8	HDMIRX_SCL_M0			G	4	up	I	
GPIO1_B3/HDMIRX_CEC_M0	K9	HDMIRX_CEC_M0			G	4	up	I	
GPIO2_A0/VOP_D0	G10	VOP_D0			I	12	down	I	GPIO
GPIO2_A1/VOP_D1	G11	VOP_D1			I	12	down	I	
GPIO2_A2/VOP_D2	G12	VOP_D2			I	12	down	I	
GPIO2_A3/VOP_D3	F9	VOP_D3			I	12	down	I	
GPIO2_A4/VOP_D4	F12	VOP_D4			I	12	down	I	
GPIO2_A5/VOP_D5	F11	VOP_D5			I	12	down	I	
GPIO2_A6/VOP_D6	F10	VOP_D6			I	12	down	I	
GPIO2_A7/VOP_D7	E10	VOP_D7			I	12	down	I	
GPIO2_B0/VOP_D8	E12	VOP_D8			I	12	down	I	
GPIO2_B1/VOP_D9	E11	VOP_D9			I	12	down	I	
GPIO2_B2/VOP_D10	D10	VOP_D10			I	12	down	I	
GPIO2_B3/VOP_D11	D11	VOP_D11			I	12	down	I	
GPIO2_B4/VOP_D12	C11	VOP_D12			I	12	down	I	

Pad#	Ball#	func1	func2	func3	Pad Type ^o	Drive Strength ^o	Pull	Reset State ^o	Power Supply
GPIO2_B5/VOP_D13	D12	VOP_D13			I	12	down	I	Power Supply
GPIO2_B6/VOP_D14	C12	VOP_D14			I	12	down	I	
GPIO2_B7/VOP_D15	B12	VOP_D15			I	12	down	I	
GPIO2_C0/VOP_D16/XIPS FCCSN	B11	VOP_D16			I	12	down	I	
GPIO2_C1/VOP_D17/XIPS FCMISO	A11	VOP_D17			I	12	down	I	
GPIO2_C2/VOP_D18/XIPS FCMOSI	C10	VOP_D18			I	12	down	I	
GPIO2_C3/VOP_D19/RISC VJTAGTDO	B10	VOP_D19			I	12	down	I	
GPIO2_C4/VOP_D20/RISC VJTAGTDI	A10	VOP_D20			I	12	down	I	
GPIO2_C5/VOP_D21/RISC VJTAGCTMS	D9	VOP_D21			I	12	down	I	
GPIO2_C6/VOP_D22/RISC VJTAGTCK	C9	VOP_D22			I	12	down	I	
GPIO2_C7/VOP_D23/RISC VJTAGRTSN	C8	VOP_D23			I	12	down	I	
VOP_DCLK	A9	VOP_DCLK			I	16	down	I	
GPIO3_A0/VOP_DEN	B9	VOP_DEN			I	12	down	I	
GPIO3_A1/VOP_HSYNC	A8	VOP_HSYNC			I	12	down	I	
GPIO3_A3/VOP_VSYNC	B8	VOP_VSYNC			I	12	down	I	
GPIO3_B1/GVI_HPD	A7	GVI_HPD			C	4	up	I	
GPIO3_B2/GVI_LOCK	B7	GVI_LOCK			C	4	up	I	
HDMIRX_EXTR	G9				A	NA	NA	NA	
HDMIRX_CLKN	L11				A	NA	NA	NA	
HDMIRX_CLKP	L12				A	NA	NA	NA	
HDMIRX_D0N	K11				A	NA	NA	NA	
HDMIRX_D0P	K12				A	NA	NA	NA	
HDMIRX_D1N	J11				A	NA	NA	NA	
HDMIRX_D1P	J12				A	NA	NA	NA	
HDMIRX_D2N	H11				A	NA	NA	NA	
HDMIRX_D2P	H12				A	NA	NA	NA	
HDMITX_CLKN	L4				A	NA	NA	NA	HDMITX
HDMITX_CLKP	M4				A	NA	NA	NA	
HDMITX_D0N	L5				A	NA	NA	NA	
HDMITX_D0P	M5				A	NA	NA	NA	
HDMITX_D1N	L6				A	NA	NA	NA	
HDMITX_D1P	M6				A	NA	NA	NA	
HDMITX_D2N	L7				A	NA	NA	NA	
HDMITX_D2P	M7				A	NA	NA	NA	
HDMITX_EXTR	M3				A	NA	NA	NA	
GVI/LVDS/MIPI_REXT	B1				A	NA	NA	NA	GVI/LVDS/MIPI_TX
GVI/LVDS/MIPI_TX0N	G1				A	NA	NA	NA	
GVI/LVDS/MIPI_TX0P	G2				A	NA	NA	NA	
GVI/LVDS/MIPI_TX1N	F1				A	NA	NA	NA	
GVI/LVDS/MIPI_TX1P	F2				A	NA	NA	NA	
GVI/LVDS/MIPI_TX2N	E1				A	NA	NA	NA	
GVI/LVDS/MIPI_TX2P	E2				A	NA	NA	NA	
GVI/LVDS/MIPI_TX3N	D1				A	NA	NA	NA	
GVI/LVDS/MIPI_TX3P	D2				A	NA	NA	NA	
GVI/LVDS/MIPI_TX4N	C1				A	NA	NA	NA	
GVI/LVDS/MIPI_TX4P	C2				A	NA	NA	NA	
GVI/LVDS/MIPI_TX5N	B2				A	NA	NA	NA	
GVI/LVDS/MIPI_TX5P	A2				A	NA	NA	NA	
GVI/LVDS/MIPI_TX6N	B3				A	NA	NA	NA	
GVI/LVDS/MIPI_TX6P	A3				A	NA	NA	NA	
GVI/LVDS/MIPI_TX7N	B4				A	NA	NA	NA	
GVI/LVDS/MIPI_TX7P	A4				A	NA	NA	NA	
GVI/LVDS/MIPI_TX8N	B5				A	NA	NA	NA	

Pad#	Ball#	func1	func2	func3	Pad Type [Ⓢ]	Drive Strength [Ⓢ]	Pull	Reset State [Ⓢ]	Power Supply
GVI/LVDS/MIPI_TX8P	A5				A	NA	NA	NA	
GVI/LVDS/MIPI_TX9N	B6				A	NA	NA	NA	
GVI/LVDS/MIPI_TX9P	A6				A	NA	NA	NA	

Notes:

Ⓢ Pad types: I = input, O = output, I/O = input/output (bidirectional)

AP = Analog Power, AG = Analog Ground

DP = Digital Power, DG = Digital Ground

A = Analog

Ⓢ Output Drive Unit is mA, only Digital IO has drive value;

Ⓢ Reset state: I = input without any pull resistor, O = output without any pull resistor;

2.10 IO Pin Name Description

This sub-chapter will focus on the detailed function description of every pins based on different interface.

Table 2-4 RK628 IO Function Description List

Interface	Pin Name	Direction	Description
MISC	XIN_OSC	I	Clock input of 24MHz crystal
	XOUT_OSC	O	Clock output of 24MHz crystal
	NPOR	I	Chip hardware reset

Interface	Pin Name	Direction	Description
GVI/LVDS/MIPI_TX	GVI/LVDS/MIPI_REXT	I	External reference resistor
	GVI/LVDS/MIPI_TXiN(i=0~9)	O	Gvi/lvds/mipi Tx negative differential line driver data output
	GVI/LVDS/MIPI_TXiP(i=0~9)	O	Gvi/lvds/mipi Tx positive differential line driver data output

Interface	Pin Name	Direction	Description
HDMI_RX	HDMIRX_EXTR	I	External reference resistor
	HDMIRX_CLKN	I	HDMI clk lane N
	HDMIRX_CLKP	I	HDMI clk lane P
	HDMIRX_D0N	I	HDMI data lane 0
	HDMIRX_D0P	I	HDMI data lane 0
	HDMIRX_D1N	I	HDMI data lane 1
	HDMIRX_D1P	I	HDMI data lane 1
	HDMIRX_D2N	I	HDMI data lane 2
	HDMIRX_D2P	I	HDMI data lane 2

Interface	Pin Name	Direction	Description
HDMI_TX	HDMITX_CLKN	O	HDMI negative TMDS differential line driver clock output.
	HDMITX_CLKP	O	HDMI positive TMDS differential line driver clock output.
	HDMITX_DiN(i=0~2)	O	HDMI negative TMDS differential line driver data output.
	HDMITX_DiP(i=0~2)	O	HDMI positive TMDS differential line driver data output.

Interface	Pin Name	Direction	Description
	HDMITX_EXTR	I	Hdmi reference resistor

2.11 RK628 IO Type

The following list shows IO type except Analog IO and all of Power/Ground IO.

Table 2-5 RK628 IO Type List

Type	Diagram	Description	Pin Name
A		Analog IO Cell with IO Voltage	EFUSE
B		3-state output pad with enable controlled input and enable controlled pull-down	GPIO0_A3/I2S_LRCK_M0
C		3-state output pad with enable controlled Schmitt trigger input and pull-down	GPIO0_A2/I2S_SCK_M0
D		3-state output pad with enable controlled input and enable controlled pull-up	GPIO3_B1/GVI_HPD
E		3-state bi-direction I/O pads with controlled driving strength of low level, slew rate and uncontrolled pull-down resistor	GPIO0_B0/HDMITX_HPD
F		3-state bi-direction I/O pads with controlled driving strength of low level, slew rate and uncontrolled pull-up resistor	GPIO0_B1/HDMITX_SDA
G		3-state bi-direction I/O pads with controlled driving strength of low level, slew rate and uncontrolled Schmitt trigger, pull-up resistor	GPIO1_B0/HDMIRX_HPD_M0

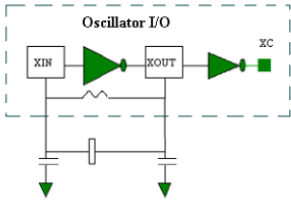
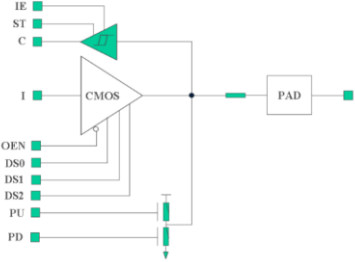
Type	Diagram	Description	Pin Name
H		CRYSTAL OSCILLATOR WITH INTERNAL RESISTOR	OSC_IN OSC_OUT
I		3-state bi-direction I/O pads with programmable drive-strength, controlled input enable, Schmitt trigger and pull-up / pull-down resistor	GPIO2_A0/VOP_D0

Chapter 3 Electrical Specification

3.1 Absolute Maximum Ratings

Table 3-1 RK628 Absolute Maximum Ratings

Parameters	Related Power Group	Max	Unit
DC supply voltage for internal digital logic@1.1v	DVDD_1,DVDD_2	1.21	V
DC supply voltage for digital GPIO@1.8V mode	VCCIO2_1 VCCIO2_2	1.89 1.89	V
DC supply voltage for digital GPIO@3.3V mode	VCCIO1 VCCIO2_1 VCCIO2_2	3.465 3.465 3.465	V
DC supply voltage for HDMI RX	HDMIRX_AVDD_3V3 HDMIRX_DVDD_1V1	3.465 1.21	V
DC supply voltage for GVI/LVDS/MIPI TX	GVI/LVDS/MIPI_PLL_AVDD_3V3 GVI/LVDS/MIPI_AVDD_3V3 GVI/LVDS/MIPI_AVDD_1V1	3.465 3.465 1.21	V
DC supply voltage for HDMI TX	HDMITX_DVDD_1V1 HDMITX_AVDD_3V3	1.21 3.465	V
DC supply voltage for PLL	PLL_AVDD_1V1 PLL_AVDD_3V3	1.21 3.465	V
DC supply voltage for EFUSE	EFUSE_VDD_2V5	2.625	V
Storage Temperature	Tstg	125	°C
Max Conjunction Temperature	Tj	125	°C

Absolute maximum ratings specify the values beyond which the device may be damaged permanently. Long-term exposure to absolute maximum ratings conditions may affect device reliability.

3.2 Recommended Operating Condition

Following table describes the recommended operating condition.

Table 3-2 RK628 Recommended Operating Condition

Parameters	Symbol	Min	Typ	Max	Unit
DC supply voltage for internal digital logic@1.1v	DVDD_1,DVDD_2	0.99	1.1	1.21	V
DC supply voltage for digital GPIO@1.8V mode	VCCIO2_1 VCCIO2_2	1.62 1.62	1.8 1.8	1.98 1.98	V
DC supply voltage for digital GPIO@3.3V mode	VCCIO1 VCCIO2_1 VCCIO2_2	3.135 3.135 3.135	3.3 3.3 3.3	3.465 3.465 3.465	V
DC supply voltage for HDMI RX	HDMIRX_AVDD_3V3 HDMIRX_DVDD_1V1	3.135 0.99	3.3 1.1	3.465 1.21	V
DC supply voltage for GVI/LVDS/MIPI TX	GVI/LVDS/MIPI_PLL_AVDD_3V3 GVI/LVDS/MIPI_AVDD_3V3 GVI/LVDS/MIPI_AVDD_1V1	3.135 3.135 0.99	3.3 3.3 1.1	3.465 3.465 1.21	V
DC supply voltage for HDMI TX	HDMITX_AVDD_3V3 HDMITX_DVDD_1V1	3.135 0.99	3.3 1.1	3.465 1.21	V
DC supply voltage for PLL	PLL_AVDD_3V3 PLL_AVDD_1V1	3.135 0.99	3.3 1.1	3.465 1.21	V
DC supply voltage for EFUSE	EFUSE_VDD_2V5	2.375	2.5	2.625	V
PLL input clock frequency		N/A	24	N/A	MHz
Operating Temperature		-40	25	125	°C

3.3 DC Characteristics

Table 3-3 RK628 DC Characteristics

Parameters		Symbol	Min	Typ	Max	Units
Digital GPIO @3.3V for GPIO0/1/2/3	Input Low Voltage	Vil	-0.3	NA	0.8	V
	Input High Voltage	Vih	2.0	NA	3.465	V
	Output Low Voltage	Vol	NA	NA	0.4	V
	Output High Voltage	Voh	2.4	NA	NA	V
	Threshold Point	Vtr+	1	1.16	1.34	V
		Vtr-	1.02	1.19	1.39	V
	Pullup Resistor	Rpu	26	46	71	Kohm
Pulldown Resistor	Rpd	27	48	102	Kohm	
Digital GPIO @1.8V for GPIO0/1/2/3	Input Low Voltage	Vil	-0.3	NA	0.58	V
	Input High Voltage	Vih	1.27	NA	3.15	V
	Output Low Voltage	Vol	NA	NA	0.45	V
	Output High Voltage	Voh	1.40	NA	NA	V
	Threshold Point	Vtr+	0.9	0.95	1.01	V
		Vtr-	0.91	0.97	1.03	V
	Pullup Resistor	Rpu	33	58	88	Kohm
Pulldown Resistor	Rpd	34	60	93	Kohm	

3.4 Recommended Operating Frequency

Table 3-4 RK628 Recommended Operating Frequency

Parameter	Condition	Symbol	Min	Typ	Max	Unit
CPLL	0.9V , 25 ℃	cppll				MHz
	0.99V , -40 ℃					
	0.81V , 125 ℃				1600	
GPLL	0.9V , 25 ℃	gppll				MHz
	0.99V , -40 ℃					
	0.81V , 125 ℃				1600	
HDMI RX CTRL	0.9V , 25 ℃	dclk_rx				MHz
	0.99V , -40 ℃					
	0.81V , 125 ℃				375	
Process	0.9V , 25 ℃	Sclk				MHz
	0.99V , -40 ℃					
	0.81V , 125 ℃				600	