

Rockchip RK3288 Datasheet

**Revision2.6
Nov. 2019**

Revision History

Date	Revision	Description
2019-11-12	2.6	Update the operation conditions
2019-3-19	2.5	Add RK3288-D information
2018-5-29	2.4	Add RK3288K and RK3288-CG W version
2017-11-21	2.3	Update
2017-3-1	2.2	Update
2016-12-29	2.1	Update
2016-11-16	2.0	Update
2015-12-29	1.9	Update
2015-12-4	1.8	Update
2015-11-24	1.7	Update
2015-7-14	1.6	Update
2015-6-2	1.5	Update
2014-11-24	1.4	Errata the AB11 typo in page.35
2014-11-1	1.3	Add RK3288-C order information Modify Operating Temperature
2014-10-9	1.2	Add CPU MAX frequency define
2014-7-15	1.1	Update package
2014-5-16	1.0	Initial Release

Table of Content

Table of Content.....	3
Figure Index.....	4
Table Index	5
NOTICE	6
Chapter 1 Introduction	7
1.1 Overview	7
1.2 Features	7
1.3 Block Diagram	22
Chapter 2 Package information	24
2.1 Ordering information	24
2.2 Top Marking:	24
2.3 Dimension	27
2.4 Ball Map	30
2.5 Ball Pin Number Order	33
2.6 Power/ground IO descriptions	42
2.7 Function IO description	45
2.8 IO pin name descriptions	59
2.9 IO Type	66
Chapter 3 Electrical Specification	67
3.1 Absolute Maximum Ratings.....	67
3.2 Recommended Operating Conditions.....	67
3.3 DC Characteristics.....	69
3.4 Electrical Characteristics for General IO.....	71
3.5 Electrical Characteristics for PLL	71
3.6 Electrical Characteristics for SAR-ADC	72
3.7 Electrical Characteristics for TSADC	72
3.8 Electrical Characteristics for USB Interface.....	72
3.9 Electrical Characteristics for USIC Interface	73
3.10 Electrical Characteristics for DDR IO.....	73
3.11 Electrical Characteristics for eFuse	73
3.12 Electrical Characteristics for HDMI	74
3.13 Electrical Characteristics for MIPI PHY	74
3.14 Electrical Characteristics for LVDS.....	75
Chapter 4 Thermal Management	76
4.1 Overview	76
4.2 Package Thermal Characteristics	76

Figure Index

Fig. 1-1 RK3288 Block Diagram	23
Fig. 2-1 RK3288 Silk Marking	24
Fig. 2-2 RK3288 W Version Silk Marking	25
Fig. 2-3 RK3288C Silk Marking	25
Fig. 2-4 RK3288K Silk Marking	25
Fig. 2-5 RK3288-CG Silk Marking.....	26
Fig. 2-6 RK3288-CG W Version Silk Marking	26
Fig. 2-7 FCBGA636LD Package Top View	27
Fig. 2-8 FCBGA636LD Package Bottom View	27
Fig. 2-9 FCBGA636LD Package Side View	27
Fig. 2-10 FCBGA636LD Package Dimension	28
Fig. 2-11 RK3288 FCCSP636LD Package Top View--EOL	28
Fig. 2-12 RK3288 FCCSP636LD Package Bottom View-EOL	28
Fig. 2-13 RK3288 FCCSP636LD Package Side View-EOL	29
Fig. 2-14 RK3288 FCCSP636LD Package Dimension-EOL	29
Fig. 2-15 RK3288 Ball Mapping Diagram	33

Table Index

Table 2-1 RK3288 Ball Pin Number Order Information	33
Table 2-2 RK3288 Power/Ground IO information	42
Table 2-3 RK3288 IO function description list.....	59
Table 2-4 RK3288 IO Type List	66
Table 3-1 RK3288 absolute maximum ratings	67
Table 3-2 RK3288 recommended operating conditions	67
Table 3-3 RK3288 DC Characteristics.....	69
Table 3-4 RK3288 Electrical Characteristics for Digital General IO	71
Table 3-5 RK3288 Electrical Characteristics for PLL	71
Table 3-6 RK3288 Electrical Characteristics for SAR-ADC	72
Table 3-7 RK3288 Electrical Characteristics for TSADC	72
Table 3-8 RK3288 Electrical Characteristics for USB Interface	72
Table 3-9 RK3288 Electrical Characteristics for USIC Interface	73
Table 3-10 RK3288 Electrical Characteristics for DDR IO	73
Table 3-11 RK3288 Electrical Characteristics for eFuse	73
Table 3-12 RK3288 Electrical Characteristics for HDMI	74
Table 3-13 RK3288 Electrical Characteristics for MIPI PHY	74
Table 3-14 RK3288 Electrical Characteristics for LVDS.....	75
Table 4-1 RK3288 Thermal Resistance Characteristics	76

NOTICE

Copyright © 2019, Fuzhou Rockchip Electronics Co., Ltd. All rights reserved.

1. By using this document, you hereby unequivocally acknowledge that you have read and agreed to be bound by the contents of this notice.
2. Fuzhou Rockchip Electronics Co., Ltd. ("Rockchip") may make changes to any information in this document at any time without any prior notice. The information herein is subject to change without notice. Do not finalize a design with this information.
3. Information in this document is provided in connection with Rockchip products.
4. THIS DOCUMENT IS PROVIDED "AS IS" WITHOUT ANY WARRANTY OR CONDITION OF ANY KIND, EITHER EXPRESS, IMPLIED OR STATUTORY, INCLUDING, WITHOUT LIMITATION, ANY WARRANTY OR CONDITION WITH RESPECT TO MERCHANTABILITY, FITNESS FOR ANY PARTICULAR PURPOSE, OR NON-INFRINGEMENT. ROCKCHIP DOES NOT ASSUME ANY RESPONSIBILITY AND LIABILITY FOR ITS USE NOR FOR ANY INFRINGEMENT OF PATENTS OR OTHER RIGHTS OF THE THIRD PARTIES WHICH MAY RESULT FROM ITS USE.
5. Rockchip products described in this document are not designed, intended for use in medical, life saving, life sustaining, critical control or safety systems, or in nuclear facility application.
6. Rockchip and Rockchip logo are trademarks or registered trademarks of Rockchip in China and other countries. All referenced brands, product names, service names and trademarks in this document are the property by their respective owners.

Chapter 1 Introduction

1.1 Overview

RK3288 are low power, high performance processor for mobile phones, personal mobile internet device and other digital multimedia applications, and integrates quad-core Cortex-A17 with separately NEON coprocessor.

Many embedded powerful hardware engines provide optimized performance for high-end application. RK3288 supports almost full-format; include H.265 decoder by 2160p@60fps, H.264 decoder by 2160p@24fps, also support H.264/MVC/VP8 encoder by 1080p@30fps, high-quality JPEG encoder/decoder, and special image preprocessor and postprocessor.

Embedded 3D GPU makes RK3288 completely compatible with OpenGL ES1.1/2.0/3.0, OpenCL 1.2 and DirectX 11. Special 2D hardware engine with MMU will maximize display performance and provide very smoothly operation.

RK3288 has high-performance dual channel external memory interface (DDR3/DDR3L /LPDDR2/LPDDR3) capable of sustaining demanding memory bandwidth, also provides a complete set of peripheral interface to support very flexible applications.

RK3288 LOT NO# end with "W" is upgraded version, could support HDCP2.2 and USB 1.1.

1.2 Features

The features listed below which may or may not be present in actual product, may be subject to the third party licensing requirements. Please contact Rockchip for actual product feature configurations and licensing requirements.

1.2.1 MicroProcessor

- Quad-core ARM Cortex-A17 MPCore processor, a high-performance, low-power and cached application processor
- Full implementation of the ARM architecture v7-A instruction set, ARM Neon Advanced SIMD (single instruction, multiple data) support for accelerated media and signal processing computation
- Superscalar, variable length, out-of-order pipeline with dynamic branch prediction, 8-stage pipeline
- Include VFP v3 hardware to support single and double-precision add, subtract, divide, multiply and accumulate, and square root operations
- SCU ensures memory coherency between the four CPUs
- Integrated 32KB L1 instruction cache , 32KB L1 data cache with 4-way set associative
- 1MB unified L2 Cache
- Trust zone technology support
- Full coresight debug solution
 - Debug and trace visibility of whole systems
 - ETM trace support
 - Invasive and non-invasive debug
- Six separate power domains for every core to support internal power switch and externally turn on/off based on different application scenario
 - PD_A17_0: 1st Cortex-A17 + Neon + FPU + L1 I/D Cache
 - PD_A17_1: 2nd Cortex-A17 + Neon + FPU + L1 I/D Cache
 - PD_A17_2: 3rd Cortex-A17 + Neon + FPU + L1 I/D Cache
 - PD_A17_3: 4th Cortex-A17 + Neon + FPU + L1 I/D Cache
 - PD_SCU: SCU + L2 Cache controller, and including PD_A17_0, PD_A17_1, PD_A17_2, PD_A17_3, debug logic
- One isolated voltage domain to support DVFS

1.2.2 Memory Organization

- Internal on-chip memory
 - BootRom
 - Internal SRAM for security and non-security access
- External off-chip memory^①
 - Dual channel DDR3/DDR3L
 - Dual channel LPDDR2
 - Dual channel LPDDR3
 - Dual channel async Nand Flash(include LBA Nand)
 - Single channel async Nand Flash(include LBA Nand)
 - Dual channel sync ONFI/toggle Nand Flash

1.2.3 Internal Memory

- Internal BootRom
 - Size : 20KB
 - Support system boot from the following device :
 - ◆ 8bits Async Nand Flash
 - ◆ 8bits Toggle Nand Flash
 - ◆ SPI interface
 - ◆ eMMC interface
 - ◆ SDMMC interface
 - Support system code download by the following interface:
 - ◆ USB OTG interface
- Internal SRAM
 - Size : 100KB
 - Support security and non-security access
 - Security or non-security space is software programmable
 - Security space can be 0KB,4KB,8KB,12KB,16KB, ... up to 96KB by 4KB step

1.2.4 External Memory or Storage device

- Dynamic Memory Interface (DDR3/DDR3L/LPDDR2/LPDDR3)
 - Compatible with JEDEC standard DDR3-1333/DDR3L-1333/LPDDR2-1066/LPDDR3-1066 SDRAM
 - Support 2 channel, each channel 16 or 32bits data widths
 - Support up to 2 ranks (chip selects) for each channel, totally 4GB (max) address space, maximum address space for one rank of channel 0 is also 4GB, which is software-configurable.
 - 16bits/32bits data width is software programmable
 - Programmable timing parameters to support DDR3/DDR3L/LPDDR2/LPDDR3 SDRAM from various vendor
 - Advanced command reordering and scheduling to maximize bus utilization
 - Low power modes, such as power-down and self-refresh for DDR3/LPDDR2/LPDDR3 SDRAM; clock stop and deep power-down for LPDDR2 SDRAM
 - Embedded dynamic drift detection in the PHY to get dynamic drift compensation with the controller
 - Programmable output and ODT impedance with dynamic PVT compensation
 - Support one low-power work mode: power down DDR PHY and most of DDR IO except two cs and cke output signals, make SDRAM still in self-refresh state to prevent data missing.
- Nand Flash Interface
 - Support dual channel async Nand Flash, each channel 8bits, up to 4 banks
 - Support dual channel sync DDR Nand Flash, each channel 8bits, up to 4 banks
 - Support LBA Nand Flash in async or sync mode
 - Up to 60bits hardware ECC

- For ToggleNand Flash, support DLL bypass and 1/4 or 1/8 clock adjust, maximum clock rate is 75MHz
- For async Nand Flash, support configurable interface timing , maximum data rate is 16bit/cycle
- Embedded special DMA interface to do data transfer
- Also support data transfer together with general PERI_DMACH in SoC system

- eMMC Interface
 - Compatible with standard iNAND interface
 - Support MMC4.5 protocol
 - Provide eMMC boot sequence to receive boot data from external eMMC device
 - Support FIFO over-run and under-run prevention by stopping card clock automatically
 - Support CRC generation and error detection
 - Embedded clock frequency division control to provide programmable baud rate
 - Support block size from 1 to 65535Bytes
 - 8bits data bus width

- SD/MMC Interface
 - Compatible with SD3.0, MMC ver4.5
 - Support FIFO over-run and under-run prevention by stopping card clock automatically
 - Support CRC generation and error detection
 - Embedded clock frequency division control to provide programmable baud rate
 - Support block size from 1 to 65535Bytes
 - Data bus width is 4bits

1.2.5 System Component

- CRU (clock & reset unit)
 - Support clock gating control for individual components inside RK3288
 - One oscillator with 24MHz clock input and 5 embedded PLLs
 - Up to 2.2GHz clock output for all PLLs
 - Support global soft-reset control for whole SOC, also individual soft-reset for every components

- PMU(power management unit)
 - Multiple-configurable work modes to save power by different frequency or automatical clock gating control or power domain on/off control
 - Lots of wakeup sources in different mode
 - 4 separate voltage domains
 - 12 separate power domains, which can be power up/down by software based on different application scenes

- Timer
 - 8 on-chip 64bits Timers in SoC with interrupt-based operation
 - Provide two operation modes: free-running and user-defined count
 - Support timer work state checkable
 - Fixed 24MHz clock input

- PWM
 - Four on-chip PWMs with interrupt-based operation
 - Programmable pre-scaled operation to bus clock and then further scaled
 - Embedded 32-bit timer/counter facility
 - Support capture mode
 - Support continuous mode or one-shot mode
 - Provides reference mode and output various duty-cycle waveform

- Watch Dog
 - 32 bits watchdog counter width
 - Counter clock is from apb bus clock
 - Counter counts down from a preset value to 0 to indicate the occurrence of a timeout
 - WDT can perform two types of operations when timeout occurs:
 - ◆ Generate a system reset
 - ◆ First generate an interrupt and if this is not cleared by the service routine by the time a second timeout occurs then generate a system reset
 - Programmable reset pulse length
 - Totally 16 defined-ranges of main timeout period

- Interrupt Controller
 - Support 3 PPI interrupt source and 112 SPI interrupt sources input from different components inside RK3288
 - Support 16 software-triggered interrupts
 - Input interrupt level is fixed , only high-level sensitive
 - Two interrupt outputs (nFIQ and nIRQ) separately for eachCortex-A17, both are low-level sensitive
 - Support different interrupt priority for each interrupt source, and they are always software-programmable

- DMAC
 - Micro-code programming based DMA
 - The specific instruction set provides flexibility for programming DMA transfers
 - Linked list DMA function is supported to complete scatter-gather transfer
 - Support internal instruction cache
 - Embedded DMA manager thread
 - Support data transfer types with memory-to-memory, memory-to-peripheral, peripheral-to-memory
 - Signals the occurrence of various DMA events using the interrupt output signals
 - Mapping relationship between each channel and different interrupt outputs is software-programmable
 - Two embedded DMA controller, BUS_DMAC is for bus system, PERI_DMAC is for peripheral system
 - BUS_DMAC features:
 - ◆ 6 channels totally
 - ◆ 6 hardware request from peripherals
 - ◆ 2 interrupt output
 - ◆ Dual APB slave interface for register config, designated as secure and non-secure
 - ◆ Support trustzone technology and programmable secure state for each DMA channel
 - PERI_DMAC features:
 - ◆ 7 channels totally
 - ◆ 9 hardware request from peripherals
 - ◆ 2 interrupt output
 - ◆ Not support trustzone technology

- Security system
 - Support trustzone technology for the following components inside RK3288
 - ◆ Cortex-A17, support security and non-security mode, switch by software
 - ◆ BUS_DMAC, support some dedicated channels work only in security mode
 - ◆ eFuse, only accessed by Cortex-A17 in security mode
 - ◆ Internal memory , part of space is addressed only in security mode, detailed size

- is software-programmable together with TZMA(trustzone memory adapter) and TZPC(trustzone protection controller)
- Embedded encryption and decryption engine
 - ◆ Support AES 128/192/256 bits key mode, ECB/CBC/CTR chain mode, Slave/FIFO mode
 - ◆ Support DES/3DES (ECB and CBC chain mode) , 3DES (EDE/ EEE key mode), Slave/FIFO mode
 - ◆ Support SHA1/SHA256/MD5 (with hardware padding) HASH function, FIFO mode only
 - ◆ Support 160 bit Pseudo Random Number Generator (PRNG)
 - ◆ Support 256 bit True Random Number Generator (PRNG)
- Support PKA 512/1024/2048 bit Exp ModulatorSupport security boot
- Support security debug

1.2.6 Video CODEC

- Shared internal memory and bus interface for video decoder and encoder②
- Embedded memory management unit(MMU)
 - Real-time video decoder of MPEG-1, MPEG-2, MPEG-4,H.263, H.264, AVS, VC-1, VP8, MVC
 - Error detection and concealment support for all video formats
 - Output data format is YUV420 semi-planar, and YUV400(monochrome) is also supported for H.264
 - H.264 up to HP level 5.1 : 2160p@24fps (3840x2160)③
 - MPEG-4 up to ASP level 5: 1080p@60fps (1920x1088)
 - MPEG-2 up to MP : 1080p@60fps (1920x1088)
 - MPEG-1 up to MP : 1080p@60fps (1920x1088)
 - H.263 : 576p@60fps(720x576)
 - VC-1 up to AP level 3 : 1080p@30fps (1920x1088)
 - VP8 : 1080p@60fps (1920x1088)
 - AVS : 1080p@60fps (1920x1088)
 - MVC : 1080p@60fps (1920x1088)
 - For AVS, 4:4:4 sampling not supported
 - For H.264, image cropping not supported
 - For MPEG-4,GMC(global motion compensation)not supported
 - For VC-1, upscaling and range mapping are supported in image post-processor
 - For MPEG-4 SP/H.263, using a modified H.264 in-loop filter to implement deblocking filter in post-processor unit

1.2.7 Video Encoder

- Support video encoder for H.264 (BP@level4.0, MP@level4.0, HP@level4.0), MVC and VP8
- Only support I and P slices, not B slices
- Support error resilience based on constrained intra prediction and slices
- Input data format:
 - ◆ YCbCr 4:2:0 planar
 - ◆ YCbCr 4:2:0 semi-planar
 - ◆ YCbYCr 4:2:2
 - ◆ CbYCrY 4:2:2 interleaved
 - ◆ RGB444 and BGR444
 - ◆ RGB555 and BGR555
 - ◆ RGB565 and BGR565
 - ◆ RGB888 and BRG888
 - ◆ RGB101010 and BRG101010
- Image size is from 96x96 to 1920x1088(Full HD)
- Maximum frame rate is up to 30fps@1920x1080③
- Bit rate supported is from 10Kbps to 20Mbps

1.2.8 HEVC Decoder

- Main/Main10 HEVC/H.265 decoder, 4k@60FPS
- Support up to 4096x2304 resolution
- Embedded memory management unit(MMU)
- Stream error detector (28 IDs)
- Internal 128k cache for bandwidth reduction
- Multi-clock domains and auto clock-gating design for power saving

1.2.9 JPEG CODEC

- JPEG decoder
 - Input JPEG file : YCbCr 4:0:0, 4:2:0, 4:2:2, 4:4:0, 4:1:1 and 4:4:4 sampling formats
 - Output raw image : YCbCr 4:0:0, 4:2:0, 4:2:2, 4:4:0, 4:1:1 and 4:4:4 semi-planar
 - Decoder size is from 48x48 to 8176x8176(66.8Mpixels)
 - Support JPEG ROI(region of image) decode
 - Maximum data rate④ is up to 76million pixels per second
 - Embedded memory management unit(MMU)
- JPEG encoder
 - Input raw image :
 - ◆ YCbCr 4:2:0 planar
 - ◆ YCbCr 4:2:0 semi-planar
 - ◆ YCbYCr 4:2:2
 - ◆ CbYCrY 4:2:2 interleaved
 - ◆ RGB444 and BGR444
 - ◆ RGB555 and BGR555
 - ◆ RGB565 and BGR565
 - ◆ RGB888 and BRG888
 - ◆ RGB101010 and BRG101010
 - Output JPEG file: JFIF file format 1.02 or Non-progressive JPEG
 - Encoder image size up to 8192x8192(64million pixels) from 96x32
 - Maximum data rate④ up to 90million pixels per second
 - Embedded memory management unit(MMU)

1.2.10 Image Enhancement

- Image pre-processor
 - Only used together with HD video encoder inside RK3288, not support stand-alone mode
 - Provides RGB to YCbCr 4:2:0 color space conversion, compatible with BT601, BT709 or user defined coefficients
 - Provides YCbCr4:2:2 to YCbCr4:2:0 color space conversion
 - Support cropping operation from 8192x8192 to any supported encoding size
 - Support rotation with 90 or 270 degrees
- Video stabilization
 - Work in combined mode with HD video encoder inside RK3288 and stand-alone mode
 - Adaptive motion compensation filter
 - Support scene detection from video sequence, encodes key frame when scene change noticed
- Image Post-Processor(embedded inside video decoder)
 - Combined with HD video decoder and JPEG decoder, post-processor can read input data directly from decoder output to reduce bus bandwidth

- Also work as a stand-alone mode, its input data is from image data stored in external memory
 - Input data format:
 - ◆ Any format generated by video decoder in combined mode
 - ◆ YCbCr 4:2:0 semi-planar
 - ◆ YCbCr 4:2:0 planar
 - ◆ YCbYCr 4:2:2
 - ◆ YCrYCb 4:2:2
 - ◆ CbYCrY 4:2:2
 - ◆ CrYCbY 4:2:2
 - Output data format:
 - ◆ YCbCr 4:2:0 semi-planar
 - ◆ YCbYCr 4:2:2
 - ◆ YCrYCb 4:2:2
 - ◆ CbYCrY 4:2:2
 - ◆ CrYCbY 4:2:2
 - ◆ Fully configurable ARGB channel lengths and locations inside 32bits, such as ARGB8888, RGB565, ARGB4444 etc.
 - Input image size:
 - ◆ Combined mode: from 48x48 to 8176x8176 (66.8Mpixels)
 - ◆ Stand-alone mode: width from 48 to 8176, height from 48 to 8176, and maximum size limited to 16.7Mpixels
 - ◆ Step size is 16 pixels
 - Output image size: from 16x16 to 1920x1088 (horizontal step size 8, vertical step size 2)
 - Support image up-scaling:
 - ◆ Bicubic polynomial interpolation with a four-tap horizontal kernel and a two-tap vertical kernel
 - ◆ Arbitrary non-integer scaling ratio separately for both dimensions
 - ◆ Maximum output width is 3x input width
 - ◆ Maximum output height is 3x input height
 - Support image down-scaling:
 - ◆ Arbitrary non-integer scaling ratio separately for both dimensions
 - ◆ Unlimited down-scaling ratio
 - Support YUV to RGB color conversion, compatible with BT.601-5, BT.709 and user definable conversion coefficient
 - Support dithering (2x2 ordered spatial dithering) for 4/5/6bit RGB channel precision
 - Support programmable alpha channel and alpha blending operation with the following overlay input formats:
 - ◆ 8bit alpha +YUV444, big endian channel order with AYUV8888
 - ◆ 8bit alpha +24bit RGB, big endian channel order with ARGB8888
 - Support deinterlacing with conditional spatial deinterlace filtering, only compatible with YUV420 input format
 - Support RGB image contrast/brightness/color saturation adjustment
 - Support image cropping & digital zoom only for JPEG or stand-alone mode
 - Support picture in picture
 - Support image rotation (horizontal flip, vertical flip, rotation 90,180 or 270 degrees)
- Image Enhancement-Processor (IEP)
 - Image format
 - ◆ Input data: XRGB/RGB565/YUV420/YUV422
 - ◆ Output data: ARGB/RGB565/YUV420/YUV422
 - ◆ The format ARGB/XRGB/RGB565/YUV support swap
 - ◆ Support YUV semi-planar/planar
 - ◆ Support BT601_l/BT601_f/BT709_l/BT709_f color space conversion
 - ◆ Support RGB dither up/down conversion
 - ◆ Support YUV up/down sampling conversion

- ◆ Max source image resolution: 8192x8192
- ◆ Max scaled image resolution: 4096x4096
- Enhancement
 - ◆ Gamma adjustment with programmable mapping table
 - ◆ Hue/Saturation/Brightness/Contrast enhancement
 - ◆ Color enhancement with programmable coefficient
 - ◆ Detail enhancement with filter matrix up to 9x9
 - ◆ Edge enhancement with filter matrix up to 9x9
 - ◆ Programmable difference table for detail enhancement
 - ◆ Programmable distance table for detail and edge enhancement
- Noise reduction
 - ◆ Compression noise reduction with filter matrix up to 9x9
 - ◆ Programmable difference table for compression noise reduction
 - ◆ Programmable distance table for compression noise reduction
 - ◆ Spatial sampling noise reduction
 - ◆ Temporal sampling noise reduction
 - ◆ Optional coefficient for sampling noise reduction
- Scaling
 - ◆ Horizontal down-scaling with vertical down-scaling
 - ◆ Horizontal down-scaling with vertical up-scaling
 - ◆ Horizontal up-scaling with vertical down-scaling
 - ◆ Horizontal up-scaling with vertical up-scaling
 - ◆ Arbitrary non-integer scaling ratio, from 1/16 to 16
- Deinterlace
 - ◆ Input 4 fields, output 2 frames mode
 - ◆ Input 4 fields, output 1 frames mode
 - ◆ Input 2 fields, output 1 frames mode
 - ◆ Programmable motion detection coefficient
 - ◆ Programmable high frequency factor
 - ◆ Programmable edge interpolation parameter
 - ◆ Source width up to 1920
- Interface
 - ◆ Programmable direct path to VOP
- Embedded memory management unit(MMU)

1.2.11 Graphics Engine

- 3D Graphics Engine :
 - ARM Mali-T764 GPU core
 - High performance OpenGL ES1.1/2.0/3.0, OpenCL 1.2, DirectX 11(W version only)
 - Embedded 4 shader cores with shared hierarchical tiler
 - Provide MMU and L2 Cache with 256KB size
 - Image quality using double-precision FP64, and anti-aliasing
- 2D Graphics Engine (RGA2):
 - BitBlit with Stretch Blit, Simple Blit and Filter Blit
 - Color fill with gradient fill, and pattern fill
 - Line drawing with anti-aliasing and specified width
 - High-performance stretch and shrink
 - Monochrome expansion for text rendering
 - ROP2,ROP3,ROP4
 - Alpha blending modes including global alpha, per pixel alpha, porter-duff and fading
 - 8K x 8K input and 2K x 2K output raster 2D coordinate system
 - Arbitrary degrees rotation with anti-aliasing on every 2D primitive
 - Blending, scaling and rotation are supported in one pass for Bitbilt
 - Source format:

- ◆ ABGR8888, XBGR888, ARGB8888, XRGB888
- ◆ RGB888, RGB565
- ◆ RGBA5551, RGBA4444
- ◆ YUV420 planar, YUV420 semi-planar
- ◆ YUV422 planar, YUV422 semi-planar
- ◆ BPP8, BPP4, BPP2, BPP1
- Destination formats:
 - ◆ ABGR8888, XBGR888, ARGB8888, XRGB888
 - ◆ RGB888, RGB565
 - ◆ RGBA5551, RGBA4444
 - ◆ YUV420 planar, YUV420 semi-planar only in filter and pre-scale mode
 - ◆ YUV422 planar, YUV422 semi-planar only in filter and pre-scale mode

1.2.12 Video IN/OUT

- Camera Interface(DVP interface only)
 - Support up to 5M pixels
 - 8bits BT656(PAL/NTSC) interface
 - 16bits BT601 DDR interface
 - 8bits/10bits/12bits raw data interface
 - YUV422 data input format with adjustable YUV sequence
 - YUV422,YUV420 output format with separately Y and UV space
 - Support picture in picture (PIP)
 - Support simple image effects such as arbitrary (sepia), Negative, Art freeze, Embossing etc.
 - Support static histogram statistics and white balance statistics
 - Support image crop with arbitrary windows
 - Support scale up/down from 1/8 to 8 with arbitrary non-integer ratio
- Camera Interface and Image Processor(Interface and Image Processing)
 - Maximum input resolution of 14M(4416x3312) pixels
 - Main scaler with pixel-accurate up- and down-scaling to any resolution between 4416x3312 and 32x16 pixel in processing mode
 - Self scaler with pixel-accurate up- and down-scaling to any resolution between 1920x1080 and 32x16 pixel in processing mode
 - support of semiplanar NV21 color storage format
 - support of independent image cropping on main and self path
 - ITU-R BT 601/656 compliant video interface supporting YCbCr or RGB Bayer data
 - 12 bit camera interface
 - 12 bit resolution per color component internally
 - YCbCr 4:2:2 processing
 - Hardware JPEG encoder incl. JFIF1.02 stream generator and programmable quantization and Huffman tables
 - Windowing and frame synchronization
 - Frame skip support for video (e.g. MPEG-4) encoding
 - Macro block line, frame end, capture error, data loss interrupts and sync. (h_start, v_start) interrupts
 - Luminance/chrominance and chrominance blue/red swapping for YUV input signals
 - Continuous resize support
 - Color processing (contrast, saturation, brightness, hue, offset, range)
 - Display-ready RGB output in self-picture path (RGB888, RGB666 and RGB565)
 - Rotation unit in self-picture path (90°, 180°, 270° and h/v flipping) for RGB output
 - Read port provided to read back a picture from system memory
 - Simultaneous picture read back, resizing and storing through self path while main path captures the camera picture
 - Black level compensation
 - Four channel Lens shade correction (Vignetting)

- Auto focus measurement
 - White balancing and black level measurement
 - Auto exposure support by brightness measurement in 5x5 sub windows
 - Defect pixel cluster correction unit (DPCC) supports on the fly and table based pixel correction
 - De-noising pre filter (DPF)
 - Enhanced color interpolation (RGB Bayer demosaicing)
 - Chromatic aberration correction
 - Combined edge sensitive Sharpening / Blurring filter (Noise filter)
 - Color correction matrix (cross talk matrix)
 - Global Tone Mapping with wide dynamic range unit (WDR)
 - Image Stabilization support and Video Stabilization Measurement
 - Flexible Histogram calculation
 - Digital image effects (Emboss, Sketch, Sepia, B/W (Grayscale), Color Selection, Negative image, sharpening)
 - Solarize effect through gamma correction
- Display Interface
 - Embedded two channel display interfaces: VOP_BIG and VOP_LIT.
 - Parallel Display interface
 - ◆ Parallel RGB LCD Interface:
 - 30-bit(RGB101010),24-bit(RGB888),18-bit(RGB666), 15-bit(RGB565)
 - ◆ Serial RGB LCD Interface(optional):
 - 2x12-bit, 3x8-bit(RGB delta support), 3x8-bit+dummy
 - ◆ MCU LCD interface(optional):
 - i-8080(up to 24-bit RGB), Hold/Auto/Bypass modes
 - ◆ TV Interface: ITU-R BT.656(8-bit, 480i/576i/1080i)
 - ◆ DDR output interface:
 - parallel RGB and 2x12-bit serial RGB
 - Single or dual clock out
 - ◆ dither down:
 - allegro,FRC
 - gamma after dither
 - ◆ Max output resolution: 3840x2160 (for VOP_BIG), 2560x1600(for VOP_LIT)
 - ◆ Scanning timing 8192x4096
 - Display process
 - ◆ Background layer:
 - programmable 24-bit color
 - ◆ Win0 (Video0) layer:
 - RGB888, ARGB888, RGB565, YCbCr422, YCbCr420, YCbCr444
 - Support virtual display
 - 1/8 to 8 scaling-down and scaling-up engine:
 - ◇ Scale up using bicubic or bilinear;
 - ◇ Scale down using bilinear or average;
 - ◇ 4 Bicubic tables : precise,spline,catrom,mitchell;
 - ◇ coord 8bit, coe 8bit signed
 - x-mirror,y-mirror
 - ◆ Win1 (Video1) layer:
 - RGB888, ARGB888, RGB565, YCbCr422, YCbCr420, YCbCr444
 - Support virtual display
 - 1/8 to 8 scaling-down and scaling-up engine
 - ◇ Scale up using bicubic or bilinear;
 - ◇ Scale down using bilinear otraverage;
 - ◇ 4 Bicubic tables : precise,spline,catrom,mitchell;
 - ◇ coord 8bit, coe 8bit signed
 - x-mirror,y-mirror
 - ◆ Win2 (UI 0) layer:

- RGB888, ARGB888, RGB565, 1/2/4/8bpp
- Support virtual display
- 4 display regions
- x-mirror,y-mirror
- ◆ Win3 (UI 1) layer:
 - RGB888, ARGB888, RGB565, 1/2/4/8bpp
 - Support virtual display
 - 4 display regions
 - x-mirror,y-mirror
- ◆ Hardware cursor:
 - RGB888, ARGB888, RGB565, 1/2/4/8bpp
 - Support two size: 32x32,64x64,or 128x128
- ◆ Overlay:
 - Win0/Win1/Win2/Win3 256 level alpha blending(support pre-multiplied alpha)
 - Win0/Win1/Win2/Win3 overlay position exchangeable
 - Win0/Win1/Win2/Win3 Transparency color key
 - Win0/Win1/Win2/Win3 global/per-pixel alpha
 - HWC 256 level alpha blending
 - HWC global/per-pixel alpha
- Others
 - ◆ 3 x 256 x 8 bits display LUTs
 - ◆ YcbCr2RGB(rec601-mpeg/rec601-jpeg/rec709/BT2020)and RGB2YcbCr
 - ◆ Support BCSH function
 - ◆ Support CABC function
 - ◆ QoS request signals
 - ◆ Gather transfer (Max 8)
 - ◆ Y/UV scheduler
 - ◆ Addr alignment
 - ◆ Support IEP direct path(win0/1/2/3)
 - ◆ Embedded memory management unit(MMU)
 - ◆ Support MIPI flow control

1.2.13 HDMI

- Single Physical Layer PHY with support for HDMI 1.4 and 2.0 operation
- For HDMI operation, support for the following:
 - Up to 1080p at 120 Hz and 4k x 2k at 60 Hz HDTV display resolutions and up to QXGA graphic display resolutions
 - 3-D video formats
 - Up to 10-bit Deep Color modes
 - Up to 18 Gbps aggregate bandwidth
 - 13.5–600 MHz input reference clock
 - HPD input analog comparator
- Link controller flexible interface with 30-, 60- or 120-bit SDR data access
- RK3288 Supports HDCP 1.4
- RK3288 W version support 4K YUV 4:2:0 output and HDCP 2.2

1.2.14 LVDS (RK3288-C has not this function)

- Comply with the TIA/EIA-644-A LVDS standard
- Combine LVTTTL IO, support LVDS/LVTTTL data output
- Support reference clock frequency range from 10Mhz to 148.5Mhz
- Support LVDS RGB 30/24/18bits color data transfer
- Support VESA/JEIDA LVDS data format transfer
- Support LVDS single channel and double channel data transfer, every channel include 5 data lanes and 1 clock lane

1.2.15 MIPI PHY

- Embedded 3 MIPI PHY, MIPI 0 only for TX, MIPI 1 for TX and RX, MIPI 2 only for RX
- Support 4 data lane, providing up to 4Gbps data rate
- Support 1080p @ 60fps output
- Lane operation ranging from 80 Mbps to 1 Gbps in forward direction

1.2.16 eDP PHY

- Support 4Kx2K @ 30fps
- Compliant with eDP TM Specification, version 1.1
- Up to 4 physical lanes of 2.7/1.62 Gbps/lane(HBR2/HBR/RBR)
- RGB, YCbCr 4:4:4, YCbCr 4:2:2 and 8/10/12 bit per component video format
- Support VESA DMT and CVT timing standards
- Fully support EIA/CEA-861D video timing and Info Frame structure
- Hot plug and unplug detection and link status monitor
- Support DDC/CI and MCCS command transmission when the monitor includes a display controller.
- Supports Panel Self Refresh(PSR)

1.2.17 Audio Interface

- I2S/PCM with 8ch
 - Support 8-channels audio transmitting in I2S mode and 2-channels in PCM mode.
 - Support 2-channels audio receiving in I2S and PCM mode
 - Audio resolution from 16bits to 32bits
 - Sample rate up to 192KHz
 - Provides master and slave work mode, software configurable
 - Support 3 I2S formats (normal, left-justified, right-justified)
 - Support 4 PCM formats(early, late1, late2, late3)
 - I2S and PCM mode cannot be used at the same time
- SPDIF
 - Support two 16-bit audio data store together in one 32-bit wide location
 - Support biphase format stereo audio data output
 - Support 16 to 31 bit audio data left or right justified in 32-bit wide sample data buffer
 - Support 16, 20, 24 bits audio data transfer in linear PCM mode
 - Support non-linear PCM transfer

1.2.18 Connectivity

- SDIO interface
 - Embedded 2 SDIO interface
 - Compatible with SDIO 3.0 protocol
 - 4bits data bus width
- High-speed ADC stream interface
 - Support single-channel 8bits/10bits interface
 - DMA-based and interrupt-based operation
 - Support 8bits TS stream interface
- TS interface
 - Supports two TS input channels and one TS output channel.
 - Supports 4 TS Input Mode: sync/valid mode in the case of serial TS input; nosync/valid mode, sync/valid, sync/burst mode in the case of parallel TS input.
 - Supports serial and parallel output mode with PCR adjustment, and lsb-msb or msb-lsb bit ordering can be chosen in the serial output mode.

- Supports 2 TS sources: demodulators and local memory.
 - Supports 2 Built-in PTIs(Programmable Transport Interface) to process TS simultaneously, and Each PTI supports:
 - ◆ 64 PID filters.
 - ◆ TS descrambling with 16 sets of Control Word under CSA v2.0 standard, up to 104Mbps
 - ◆ 16 PES/ES filters with PTS/DTS extraction and ES start code detection.
 - ◆ 4/8 PCR extraction channels
 - ◆ 64 Section filters with CRC check, and three interrupt mode: stop per unit, full-stop, recycle mode with version number check
 - ◆ PID done and error interrupts for each channel
 - ◆ PCR/DTS/PTS extraction interrupt for each channel
 - Supports 1 PVR (Personal Video Recording) output channel.
 - 1 built-in multi-channel DMA Controller.
- PS2 interface
 - Support PS/2 data communication protocol
 - Support PS/2 master mode
 - Software programmable timing requirement to support max PS/2 clockfrequency to 33KHZ
 - Support status to be queried for data communication error
 - Support interrupt mode for data communication finish
 - Support timeout mechanism for data communication
 - Support interrupt mode for data communication timeout
- Smart Card
 - support card activation and deactivation
 - support cold/warm reset
 - support Answer to Reset (ATR) response reception
 - support T0 for asynchronous half-duplex character transmission
 - support T1 for asynchronous half-duplex block transmission
 - support automatic operating voltage class selection
 - support adjustable clock rate and bit (baud) rate
 - support configurable automatic byte repetition
- Host interface
 - Low Pin Count interface(8 inputs/16 outputs or 16 inputs/8 outputs)
 - No mandatory Tri-State signals
 - All signals driven using source synchronous clock.(2 DDR clock signals per direction for TX and RX paths)
 - Low latency through serialization/deserialization
 - Transport clocks and bus clock are independent
 - Support Asymmetric(Host/Peripheral) communication operations
 - Support multiple outstanding transactions reads, writes and interrupts
 - Support Mirror Mode to enable self test with identical device
- GPS Interface
 - Single chip, integrate GPS bb with cpu
 - 32 DMA channels for AHB master access
 - Complete 1-band, C/A, and NMEA-0183 compatibility
 - Support reference frequencies 16.368MHz
 - High sensitivity for indoor fixes
 - Low power consumption
 - Low cost with smaller size
 - Multi modes support both standalone GPS and A_GPS

- GMAC 10/100/1000M Ethernet Controller
 - Supports 10/100/1000-Mbps data transfer rates with the RGMII interfaces
 - Supports 10/100-Mbps data transfer rates with the RMII interfaces
 - Supports both full-duplex and half-duplex operation
 - ◆ Supports CSMA/CD Protocol for half-duplex operation
 - ◆ Supports packet bursting and frame extension in 1000 Mbps half-duplex operation
 - ◆ Supports IEEE 802.3x flow control for full-duplex operation
 - ◆ Optional forwarding of received pause control frames to the user application in full-duplex operation
 - ◆ Back-pressure support for half-duplex operation
 - ◆ Automatic transmission of zero-quantum pause frame on deassertion of flow control input in full-duplex operation
 - Preamble and start-of-frame data (SFD) insertion in Transmit, and deletion in Receive paths
 - Automatic CRC and pad generation controllable on a per-frame basis
 - Options for Automatic Pad/CRC Stripping on receive frames
 - Programmable InterFrameGap (40-96 bit times in steps of 8)
 - Supports a variety of flexible address filtering modes
 - Separate 32-bit status returned for transmission and reception packets
 - Supports IEEE 802.1Q VLAN tag detection for reception frames
 - Support detection of LAN wake-up frames and AMD Magic Packet frames
 - Support checksum off-load for received IPv4 and TCP packets encapsulated by the Ethernet frame
 - Support checking IPv4 header checksum and TCP, UDP, or ICMP checksum encapsulated in IPv4 or IPv6 datagrams
 - Comprehensive status reporting for normal operation and transfers with errors
 - Automatic generation of PAUSE frame control or backpressure signal to the GMAC core based on Receive FIFO-fill (threshold configurable) level
 - Handles automatic retransmission of Collision frames for transmission
 - Discards frames on late collision, excessive collisions, excessive deferral and underrun conditions
- SPI Controller
 - 3 on-chip SPI controller inside RK3288
 - Support serial-master and serial-slave mode, software-configurable
 - DMA-based or interrupt-based operation
 - Embedded two 32x16bits FIFO for TX and RX operation respectively
 - Support 2 chip-selects output in serial-master mode
- Uart Controller
 - 5 on-chip uart controller inside RK3288
 - DMA-based or interrupt-based operation
 - For all UART, two 64Bytes FIFOs are embedded for TX/RX operation respectively
 - Support 5bit,6bit,7bit,8bit serial data transmit or receive
 - Standard asynchronous communication bits such as start, stop and parity
 - Support different input clock for uart operation to get up to 4Mbps or other special baud rate
 - Support non-integer clock divides for baud clock generation
 - Auto flow control mode is for all UART, except UART_DBG
- I2C controller
 - 6 on-chip I2C controller in RK3288
 - Multi-master I2C operation
 - Support 7bits and 10bits address mode
 - Software programmable clock frequency and transfer rate up to 400Kbit/s in the fast

- mode
 - Serial 8bits oriented and bidirectional data transfers can be made at up to 100Kbit/s in the standard mode
- GPIO
 - Totally 160 GPIOs
 - All of GPIOs can be used to generate interrupt to Cortex-A17
 - GPIO0 can be used to wakeup system from low-power mode
 - The pull direction(pullup or pulldown) for all of GPIOs are software-programmable
 - All of GPIOs are always in input direction in default after power-on-reset
 - The drive strength for all of GPIOs is software-programmable
- USB Host2.0
 - Embedded 2 USB Host2.0 interfaces
 - USB host (ECHI controller) only supports USB2.0, and USB1.1 (W version).
USB host (DW controller) support USB2.0/USB1.1.
 - Supports high-speed(480Mbps), full-speed(12Mbps) and low-speed(1.5Mbps) mode
 - Provides 16 host mode channels
 - Support periodic out channel in host mode
- USB OTG2.0
 - Compatible with USB OTG2.0 specification
 - Supports high-speed(480Mbps), full-speed(12Mbps) and low-speed(1.5Mbps) mode
 - Support up to 9 device mode endpoints in addition to control endpoint 0
 - Support up to 6 device mode IN endpoints including control endpoint 0
 - Endpoints 1/3/5/7 can be used only as data IN endpoint
 - Endpoints 2/4/6 can be used only as data OUT endpoint
 - Endpoints 8/9 can be used as data OUT and IN endpoint
 - Provides 9 host mode channels
- USIC Interface
 - Compliant with the USB2.0 Specification and Enhanced Host Controller Interface Specification 2.0
 - 1 Port USIC PHY Interface Operates in host mode
 - Built-in one 512x64 bits FIFO
 - Internal DMA with scatter/gather function

1.2.19 Others

- Temperature Sensor(TS-ADC)
 - 3 bipolar-based temperature-sensing cell embedded
 - 3-channel 12-bits SAR ADC
- SAR-ADC(Successive Approximation Register)
 - 3-channel single-ended 10-bit SAR analog-to-digital converter
- eFuse
 - Two high-density electrical Fuse is integrated: 256bits (32x8) / 1024bits (32x32)
 - Support standby mode

Notes :^① DDR3/LPDDR2/LPDDR3 are not used simultaneously as well as async and sync ddr nand flash

^② In RK3288, Video decoder (except H.265) and encoder are not used simultaneously because of shared internal buffer

^③ Actual maximum frame rate will depend on the clock frequency and system bus performance

^④ Actual maximum data rate will depend on the clock frequency and JPEG compression rate

1.2.20 Software difference for W version and others

Item	Updated	Note
USB HOST	Add OHCI feature	need SW patch to support new feature
	Fixed EHCI bug	
GPU	Support DirectX	need SW update to support new feature
VOP	Support YUV 4:2:0 output for 4K 60fps	need SW patch to support new feature
	CABC update	
PAD	Modified jtag_rstn IO default to pull-down	HW and SW compatible
VIDEO CODEC	improve VLC performance	need SW patch to support new feature
UART_DEBUG	update uart_debug default setting	SW compatible
ISP/VIP	update ISP and DVP interface	need SW patch to support new feature
RGA2	Fixed bug of RGA2 scale	SW compatible
IEP	Support 4K	need SW update to support new feature
HDMI	Add HDCP2.2 feature	need SW update to support new feature
I2C	Modified I2C IO timing	SW compatible
HDMI	Update HDMI_cecin_msk control	need SW update to support new feature
SGRF	Update SGRF reset value	SW compatible

1.3 Block Diagram

The following diagram shows the basic block diagram for RK3288.

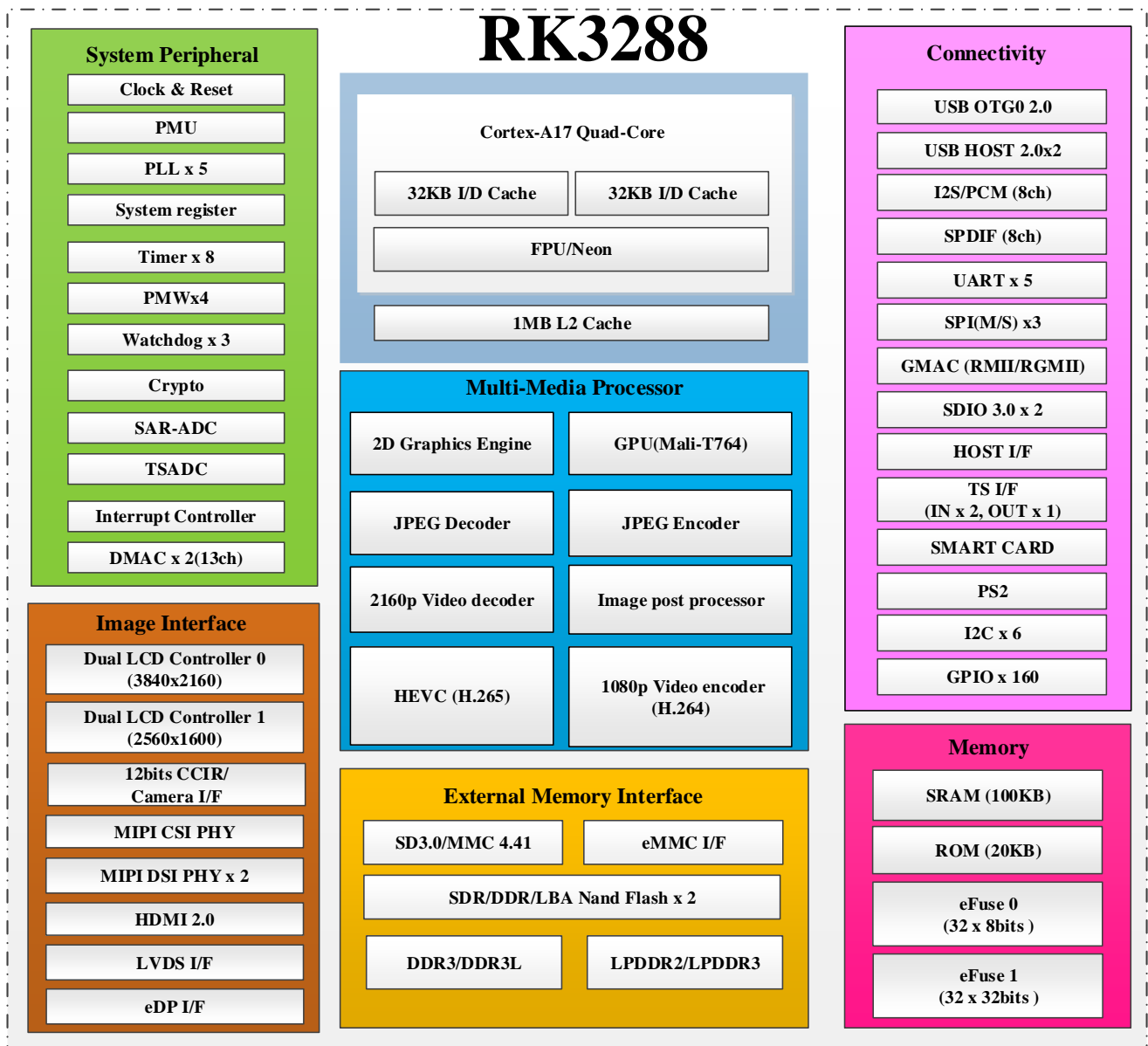

Fig. 1-1 RK3288 Block Diagram

Chapter 2 Package information

2.1 Ordering information

Orderable Device	RoHS status	Package	Package Qty	Device Feature	Available
RK3288	RoHS	FCBGA636LD	700	1.6GHz Quad core A17 AP	MP
RK3288 W Version	RoHS	FCBGA636LD	700	1.6GHz Quad core A17 AP	MP
RK3288-C	RoHS	FCBGA636LD	700	1.8GHz Quad core A17 AP For ChromeOS application	MP
RK3288K	RoHS	FCBGA636LD	700	1.8GHz Quad core A17 AP for commercial application	MP
RK3288-D	RoHS	FCBGA636LD	700	1.6GHz Quad core A17 AP with Dolby function	MP
RK3288-CG	RoHS	FCBGA636LD	700	1.8GHz Quad core A17 AP	EOL
RK3288-CG W Version	RoHS	FCBGA636LD	700	1.8GHz Quad core A17 AP	MP
RK3288	RoHS	FCCSP636LD	700	1.6GHz Quad core A17 AP	EOL

2.2 Top Marking:

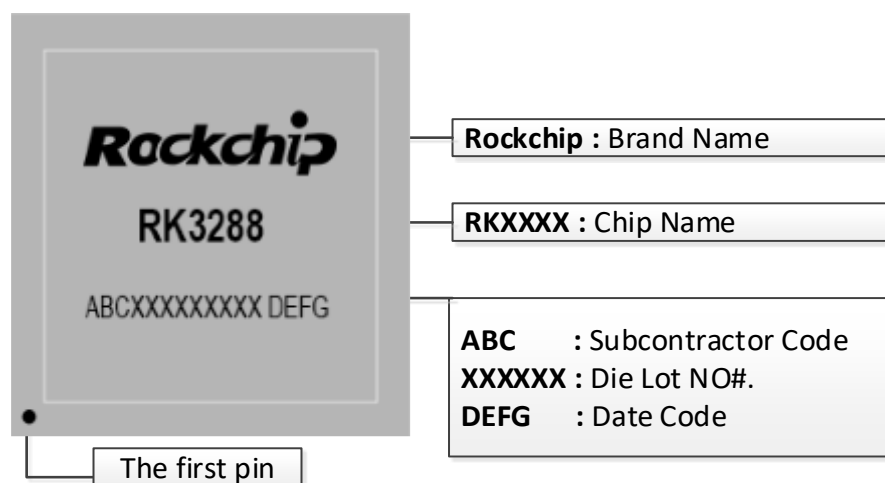

Fig. 2-1 RK3288 Silk Marking

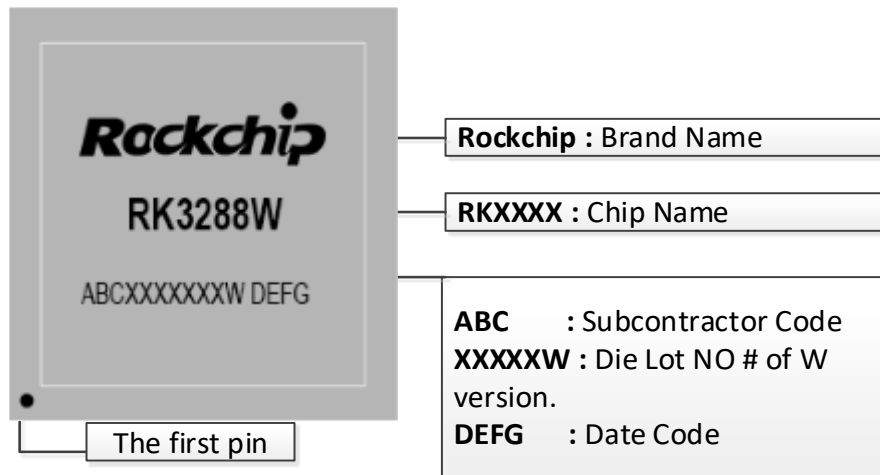

Fig. 2-2 RK3288 W Version Silk Marking

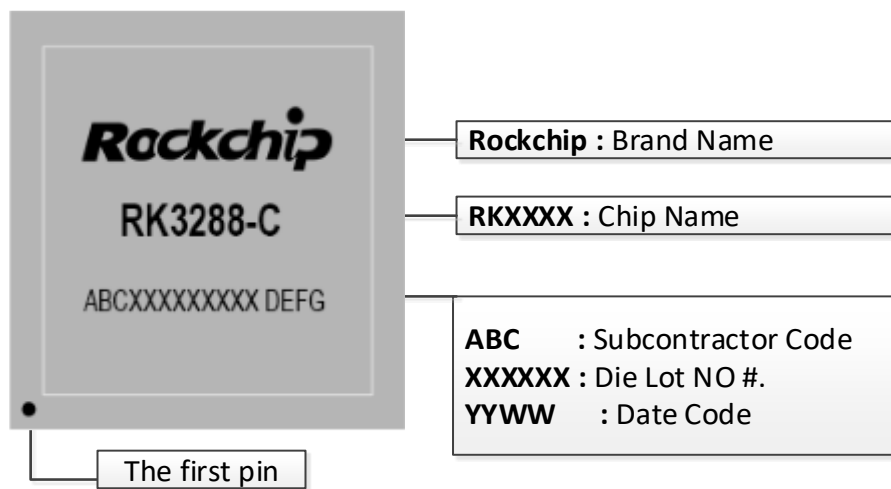

Fig. 2-3 RK3288-C Silk Marking

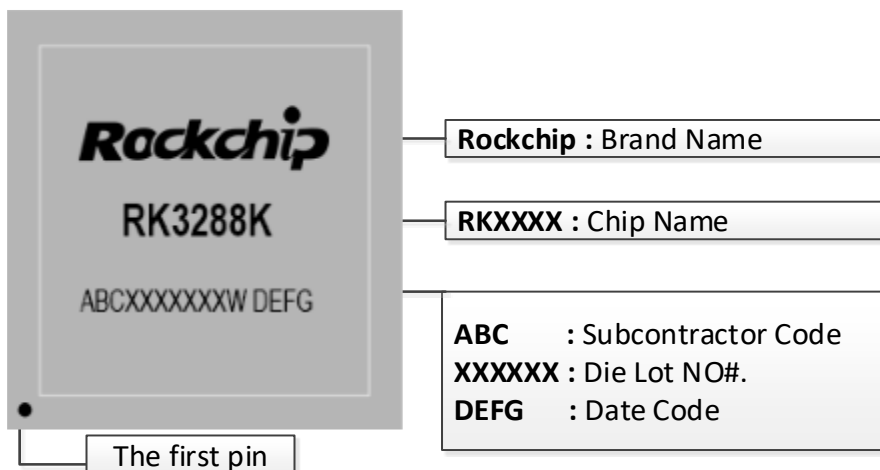

Fig. 2-4 RK3288K Silk Marking

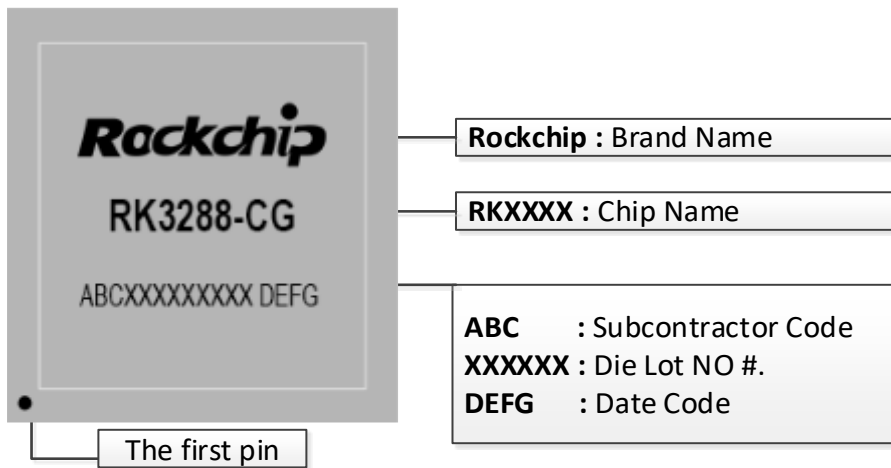

Fig. 2-5 RK3288-CG Silk Marking

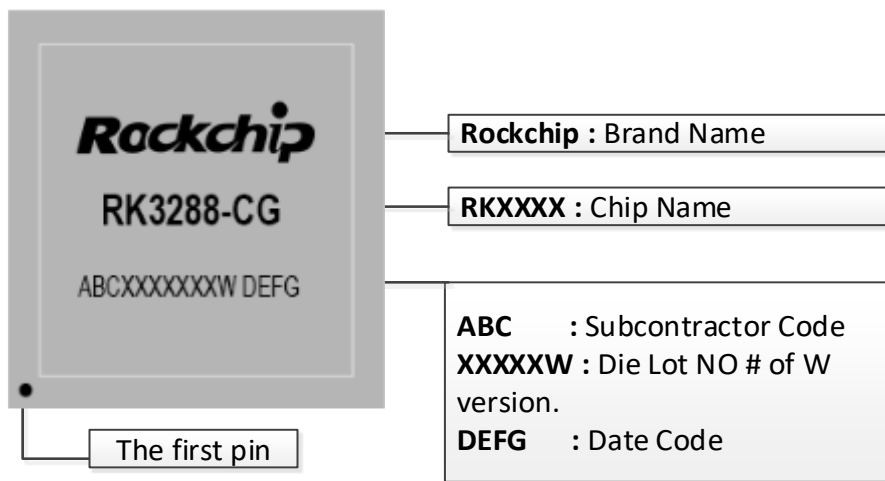

Fig. 2-6 RK3288-CG W Version Silk Marking

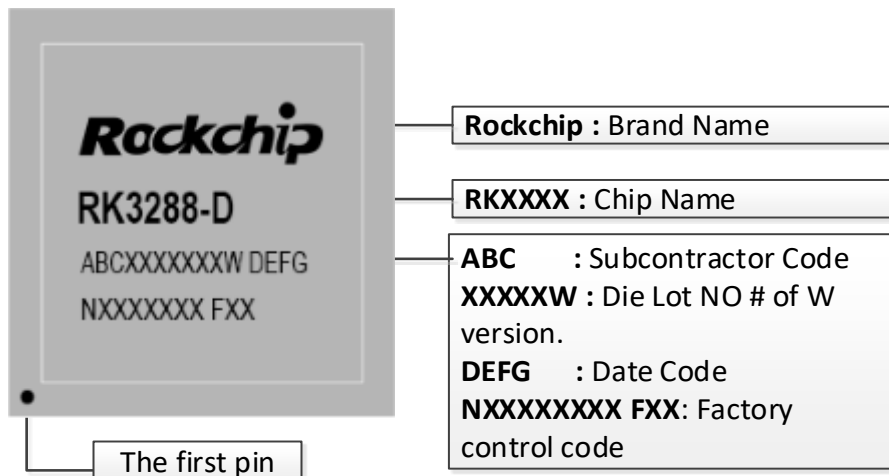

Fig. 2-7 RK3288-D Version Silk Marking

2.3 Dimension

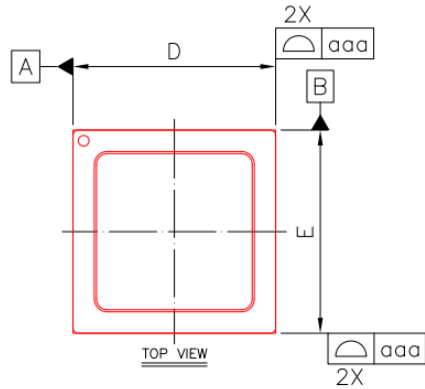

Fig. 2-8 FCBGA636LD Package Top View

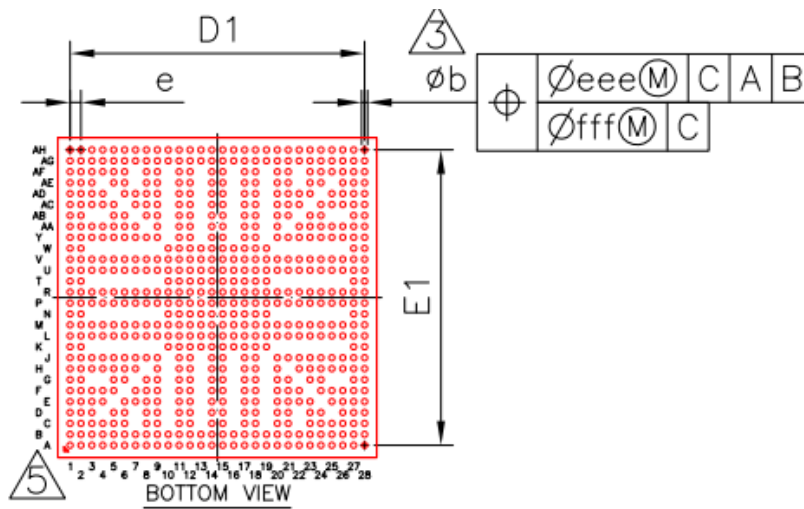

Fig. 2-9 FCBGA636LD Package Bottom View

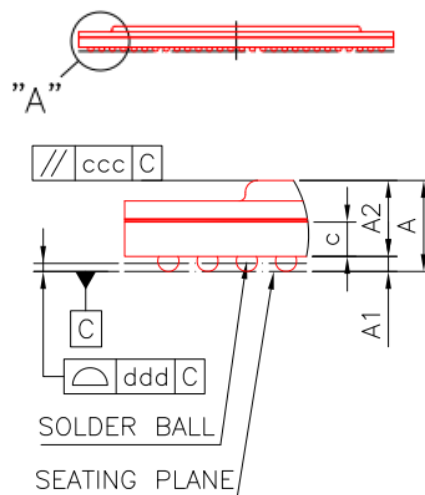

Fig. 2-10 FCBGA636LD Package Side View

Symbol	Dimension in mm			Dimension in inch		
	MIN	NOM	MAX	MIN	NOM	MAX
A	1.41	1.51	1.61	0.056	0.059	0.063
A1	0.20	0.25	0.30	0.008	0.010	0.012
A2	1.21	1.26	1.31	0.048	0.050	0.052
c	0.47	0.57	0.67	0.019	0.022	0.026
D/E	18.90	19.00	19.15	0.744	0.748	0.754
D1/E1	---	17.55	---	---	0.691	---
e	---	0.65	---	---	0.026	---
b	0.30	0.35	0.40	0.012	0.014	0.016
aaa	0.20			0.008		
ccc	0.25			0.010		
ddd	0.20			0.008		
eee	0.25			0.010		
fff	0.10			0.004		

Fig. 2-11 FCBGA636LD Package Dimension

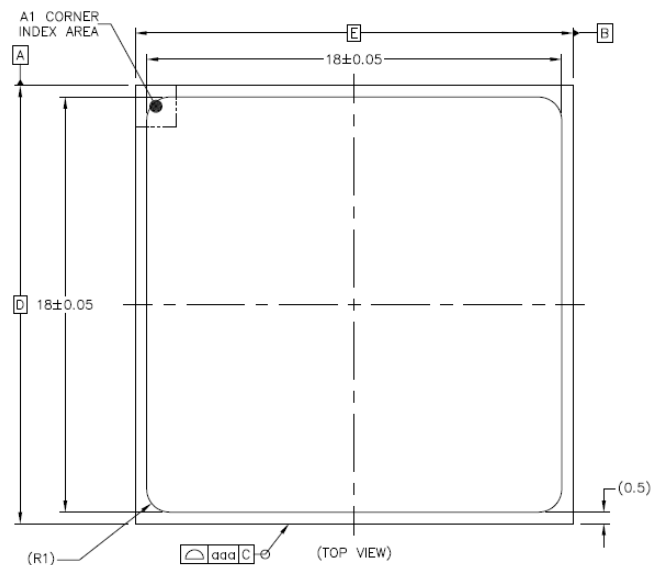

Fig. 2-12 RK3288 FCCSP636LD Package Top View--EOL

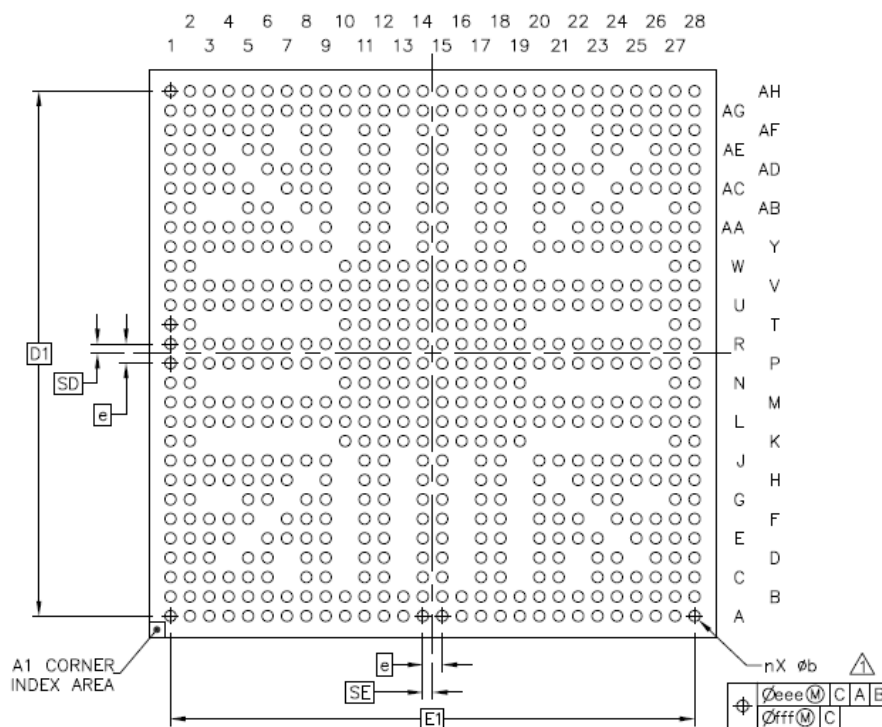

Fig. 2-13 RK3288 FCCSP636LD Package Bottom View--EOL

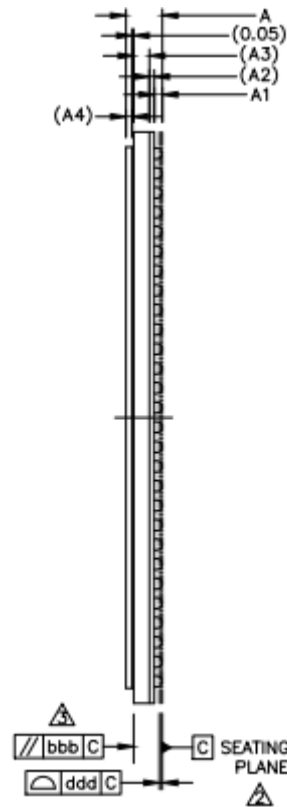

Fig. 2-14 RK3288 FCCSP636LD Package Side View-EOL

	SYMBOL	COMMON DIMENSIONS		
		MIN.	NOR.	MAX.
TOTAL THICKNESS	A	1.1	---	1.3
STAND OFF	A1	0.22	---	0.32
SUBSTRATE THICKNESS	A2		0.15	REF
MOLD THICKNESS	A3		0.53	REF
HEAT SINK THICKNESS	A4		0.2	REF
BODY SIZE	D		19	BSC
	E		19	BSC
BALL DIAMETER			0.35	
BALL OPENING			0.3	
BALL WIDTH	b	0.32	---	0.42
BALL PITCH	e		0.65	BSC
BALL COUNT	n		636	
EDGE BALL CENTER TO CENTER	D1		17.55	BSC
	E1		17.55	BSC
BODY CENTER TO CONTACT BALL	SD		0.325	BSC
	SE		0.325	BSC
PACKAGE EDGE TOLERANCE	aaa		0.15	
FLATNESS	bbb		0.2	
COPLANARITY	ddd		0.1	
BALL OFFSET (PACKAGE)	eee		0.15	
BALL OFFSET (BALL)	fff		0.08	

Fig. 2-15 RK3288 FCCSP636LD Package Dimension-EOL

2.4 Ball Map

	1	2	3	4	5	6	7	8	9	
A	DDR0_DQ25	DDR0_DQ24	DDR0_DQ10	DDR0_DQS3N	DDR0_DQ9	DDR0_DQ13	DDR0_DQS1N	DDR0_CASN	DDR0_BA1	A
B	DDR1_DQ24	DDR1_DQ25	DDR0_DM3	DDR0_DQS3	DDR0_DQ8	DDR0_DQ14	DDR0_DQS1	DDR0_CS0N	DDR0_WEN	B
C	DDR1_DQ10	DDR1_DQ30	VSS1	DDR0_DQ30	DDR0_DQ28	DDR0_DQ11	NP	DDR0_CKE1	DDR0_CKE0	C
D	DDR1_DQS3N	DDR1_DQS3	DDR1_DM3		DDR0_DQ26	VSS2	NP	DDR0_BA0	VSS3	D
E	DDR1_DQ9	DDR1_DQ8	DDR1_DQ28	DDR1_DQ26	NP	DDR0_DQ27	DDR0_DQ31	DDR0_DQ12	DDR0_RESET	E
F	DDR1_CKE0	DDR1_RESET	DDR1_DQ11	VSS12	DDR1_DQ29	NP	DDR0_DQ29	DDR0_DQ15	DDR0_DM1	F
G	DDR1_DQS1N	DDR1_DQS1	NP	NP	DDR1_DM1	DDR1_DQ27	NP	DDR0_RETLE	NC/Reserve0	G
H	DDR1_CASN	DDR1_CS0N	DDR1_CKE1	DDR1_DQ13	DDR1_DQ12	DDR1_DQ31	DDR1_RETLE	NP	DDR0_VDD1	H
J	DDR1_BA1	DDR1_WEN	DDR1_CS1N	VSS13	DDR1_DQ14	DDR1_DQ15	NC/Reserve1	DDR1_VDD1	VSS14	J
K	DDR1_A2	DDR1_A1	NP	NP	NP	NP	NP	NP	NP	K
L	DDR1_CKN	DDR1_CK	DDR1_A0	DDR1_BA0	DDR1_BA2	DDR1_RASN	NC/DDR1_ACTN	DDR1_VREFAO	DDR1_VDD2	L
M	DDR1_A6	DDR1_A5	DDR1_A7	VSS34	DDR1_A3	DDR1_A4	DDR1_ATO	DDR1_VREF	DDR1_VDD3	M
N	DDR1_A8	DDR1_A10	NP	NP	NP	NP	NP	NP	NP	N
P	DDR1_A9	DDR1_A14	DDR1_A13	DDR1_A11	DDR1_ODT0	DDR1_A12	NC/DDR1_BG0	DDR1_VDDAO	DDR1_VDD4	P
R	DDR1_A15	DDR1_ODT1	DDR1_DM2	VSS53	DDR1_DQ19	DDR1_DQ17	NC/DDR1_BG1	DDR1_DTO1	DDR1_VDD5	R
T	DDR1_DQ18	DDR1_DQ16	NP	NP	NP	NP	NP	NP	NP	T
U	DDR1_DQS2N	DDR1_DQS2	DDR1_DQ22	DDR1_DQ20	DDR1_DM0	DDR1_DQ3	DDR1_PZQ	DDR1_DTO0	VSS15	U
V	DDR1_DQ21	DDR1_DQ23	DDR1_DQ1	VSS73	DDR1_DQ6	FLASH1_D1/HOST_D1/ MAC_TXD3/SDIO1_D1/ GPIO3_D1	FLASH1_CSN2/HOST_D 15/MAC_TXCLK/SDIO1_ PWREN/GPIO4_B1	FLASH1_VDD	VSS69	V
W	DDR1_DQ4	DDR1_DQ0	NP	NP	NP	NP	NP	NP	NP	W
Y	DDR1_DQ2	DDR1_DQ5	DDR1_DQ7	FLASH1_D0/HOST_D0/ MAC_TXD2/SDIO1_D0/ GPIO3_D0	FLASH1_WRN/HOST_D 11/MAC_MDIO/GPIO4_ A5	FLASH0_RDN/GPIO3_B 2	FLASH0_CSN3/EMMC_ RSTNOUT/GPIO3_C1	GPIO3_C3/FLASH0_VOL TAGE_SEL	FLASH0_VDD	Y
AA	DDR1_DQS0N	DDR1_DQS0	FLASH1_D6/HOST_D6/ MAC_RXD0/SDIO1_BKP WR/GPIO3_D6	FLASH1_D7/HOST_D7/ MAC_RXD1/SDIO1_INT N/GPIO3_D7	FLASH1_DQS/HOST_D1 4/MAC_COL/FLASH1_ CSN3/GPIO4_B0	FLASH1_CSN1/HOST_D 13/MAC_CRS/SDIO1_CL KOUT/GPIO4_A7	UART1_TX/TS0_D1/GPI O5_B1	NP	TS0_VALID/GPIO5_C1	AA
AB	FLASH1_D2/HOST_D2/ MAC_RXD2/SDIO1_D2/ GPIO3_D2	FLASH1_D5/HOST_D5/ MAC_TXD1/SDIO1_WR PRT/GPIO3_D5	NP	NP	FLASH1_CSN0/HOST_ D12/MAC_RXCLK/SDI O1_CMD/GPIO4_A6	FLASH0_DQS/EMMC_C LKOUT/GPIO3_C2	NP	TS0_ERR/GPIO5_C3	SDMMC0_D3/JTAG_TC K/GPIO6_C3	AB
AC	FLASH1_D3/HOST_D3/ MAC_RXD3/SDIO1_D3/ GPIO3_D3	FLASH1_WP/HOST_CK OUTN/MAC_RXDV/FLA SH0_CSNA4/GPIO4_A1	FLASH1_RDY/HOST_CK OUTP/MAC_MDC/GPIO 4_A0	FLASH0_CSN2/EMMC_ CMD/GPIO3_C0	FLASH0_CSN0/GPIO3_B 6	NP	SPIO_CSNO/TS0_D5/UA RT4_RTSN/GPIO5_B5	SDMMC0_CMD/GPIO6_ C5	SDMMC0_VDD	AC
AD	FLASH1_D4/HOST_D4/ MAC_TXD0/SDIO1_DET /GPIO3_D4	FLASH1_CLE/HOST_D10 /MAC_TXEN/FLASH0_C SN7/GPIO4_A4	FLASH0_D1/EMMC_D1/ GPIO3_A1	FLASH0_CSN1/GPIO3_B 7	NP	UART1_RTSN/TS0_D3/ GPIO5_B3	SPIO_CLK/TS0_D4/UAR T4_CTSN/GPIO5_B4	SDMMC0_D2/JTAG_TDI /GPIO6_C2	GPIO4_D7	AD
AE	FLASH1_RDN/HOST_D8 /MAC_RXER/FLASH0_C SNS/GPIO4_A2	FLASH1_ALE/HOST_D9/ MAC_CLK/FLASH0_CSN 6/GPIO4_A3	FLASH0_D0/EMMC_D0/ GPIO3_A0	NP	SPIO_TXD/TS0_D6/UAR T4_TX/GPIO5_B6	TS0_CLK/GPIO5_C2	NP	SDIO0_INTN/GPIO4_D6	SDIO0_WRPRT/GPIO4_ D3	AE
AF	FLASH0_D3/EMMC_D3 /GPIO3_A3	FLASH0_D4/EMMC_D4 /GPIO3_A4	FLASH0_D2/EMMC_D2/ GPIO3_A2	FLASH0_ALE/GPIO3_B3	UART1_RX/TS0_D0/GPI O5_B0	SPIO_RXD/TS0_D7/UAR T4_RX/GPIO5_B7	NP	SDIO0_BKPWR/GPIO4_ D5	SDIO0_DET/GPIO4_D2	AF
AG	FLASH0_D6/EMMC_D6 /GPIO3_A6	FLASH0_D7/EMMC_D7 /GPIO3_A7	FLASH0_D5/EMMC_D5/ GPIO3_A5	FLASH0_WRN/GPIO3_B 5	SPIO_CSNI/TS0_SYNC/ GPIO5_C0	SDMMC0_CLKOUT/JTA G_TDO/GPIO6_C4	SDMMC0_D0/JTAG_TM S/GPIO6_C0	SDIO0_CLKOUT/GPIO4_ D1	SDIO0_D2/GPIO4_C6	AG
AH	FLASH0_WP/EMMC_P WREN/GPIO3_B1	FLASH0_RDY/GPIO3_B0	FLASH0_CLE/GPIO3_B4	UART1_CTSN/TS0_D2/ GPIO5_B2	SDMMC0_DECTN/GPIO 6_C6	SDMMC0_D1/JTAG_TR STN/GPIO6_C1	SDIO0_D3/GPIO4_C7	SDIO0_CMD/GPIO4_D0	SDIO0_D0/GPIO4_C4	AH
	1	2	3	4	5	6	7	8	9	

	10	11	12	13	14	15	16	17	18	19	
A	DDR0_A2	DDR0_CKN	DDR0_A7	DDR0_A10	DDR0_A9	DDR0_DM2	DDR0_DQ17	DDR0_DQS2N	DDR0_DQ23	DDR0_DQ4	A
B	DDR0_A0	DDR0_CK	DDR0_A5	DDR0_A8	DDR0_A14	DDR0_DQ16	DDR0_DQ19	DDR0_DQS2	DDR0_DQ21	DDR0_DQ0	B
C	NP	DDR0_A1	DDR0_A6	NP	DDR0_A13	DDR0_A15	NP	DDR0_DQ22	DDR0_DQ1	NP	C
D	NP	DDR0_RASN	VSS4	NP	DDR0_A11	VSS5	NP	DDR0_DQ20	VSS6	NP	D
E	NP	DDR0_BA2	DDR0_A3	NP	DDR0_ODT0	DDR0_ODT1	NP	DDR0_DM0	DDR0_DQ5	NP	E
F	NP	DDR0_CS1N	DDR0_A4	NP	DDR0_A12	DDR0_DQ18	NP	DDR0_DQ2	DDR0_DQ3	NP	F
G	NP	NC/DDR0_ACTN	DDR0_ATO	NP	NC/DDR0_BG0	NC/DDR0_BG1	NP	DDR0_PZQ	USB_AVDD_1V0	NP	G
H	NP	DDR0_VREFAO	DDR0_VREF	NP	DDR0_VDDAO	DDR0_DTO1	NP	DDR0_DT00	USB_AVSS1	NP	H
J	NP	DDR0_VDD2	DDR0_VDD3	NP	DDR0_VDD4	DDR0_VDD5	NP	VSS16	VSS28	NP	J
K	VSS18	VSS19	VSS20	VSS21	VSS22	VSS23	VSS24	VSS25	VSS26	VSS27	K
L	VSS29	VSS30	LOGIC_VDD1	VSS31	VSS32	VSS33	GPU_VDD1	GPU_VDD2	GPU_VDD3	GPU_VDD4	L
M	VSS35	VSS36	LOGIC_VDD2	VSS37	VSS38	GPU_VDD_COM	GPU_VDD7	GPU_VDD8	GPU_VDD9	GPU_VDD10	M
N	VSS40	VSS41	LOGIC_VDD3	VSS42	VSS43	VSS44	GPU_VDD5	GPU_VDD6	GPU_VDD11	GPU_VDD12	N
P	VSS45	VSS46	LOGIC_VDD4	VSS47	VSS48	VSS49	VSS50	VSS51	VSS52	EFUSE_VQPS	P
R	VSS54	LOGIC_VDD8	LOGIC_VDD5	VSS55	VSS61	VSS71	VSS56	VSS57	VSS58	VSS59	R
T	VSS60	LOGIC_VDD9	LOGIC_VDD6	VSS62	CPU_VDD_COM	VSS64	VSS65	VSS66	VSS67	VSS68	T
U	VSS70	LOGIC_VDD10	LOGIC_VDD7	VSS72	CPU_VDD1	CPU_VDD2	CPU_VDD3	CPU_VDD4	CPU_VDD5	CPU_VDD6	U
V	VSS74	VSS75	VSS76	VSS77	CPU_VDD7	CPU_VDD8	CPU_VDD9	CPU_VDD10	CPU_VDD11	CPU_VDD12	V
W	VSS17	VSS78	VSS79	VSS80	VSS81	VSS82	VSS83	VSS84	VSS85	VSS86	W
Y	NP	APIOS_VDD	APIO4_VDD	NP	NC/MIPI_LLI_AVDD_1V0	NC/SATA_AVDD_1V0	NP	EDP_AVDD_1V0	VSS39	NP	Y
AA	NP	APIO3_VDD	EDP_TP_OUT/SATA_R EXT	NP	NC/MIPI_LLI_AVDD_1V8	NC/SATA_AVDD_1V8	NP	EDP_AVDD_1V8	HDMI_AVDD_1V0	NP	AA
AB	NP	UART0_RTSN/GPIO4_C3	UART0_CTSN/GPIO4_C2	NP	NC/SATA_TXP	NC/SATA_TXN	NP	HDMI_REXT	HDMI_HPD	NP	AB
AC	NP	SDIO0_PWREN/GPIO4_D4	I2S_CLK/GPIO6_B0	NP	NC/SATA_RXP	NC/SATA_RXN	NP	EDP_CLK24M_IN/MIPI_LLI_REXT	EDP_REXT	NP	AC
AD	NP	I2S_SCLK/GPIO6_A0	I2C2_SCL/GPIO6_B2	NP	NC/MIPI_LLI_RX_D0P	NC/MIPI_LLI_TX_D0P	NP	NC/MIPI_LLI_RX_D1P	NC/MIPI_LLI_TX_D1P	NP	AD
AE	NP	I2S_SDI/GPIO6_A3	SPDIF_TX/GPIO6_B3	NP	NC/MIPI_LLI_RX_D0N	NC/MIPI_LLI_TX_D0N	NP	NC/MIPI_LLI_RX_D1N	NC/MIPI_LLI_TX_D1N	NP	AE
AF	NP	I2S_LRCK_TX/GPIO6_A2	I2C2_SDA/GPIO6_B1	NP	AVSS1	AVSS2	NP	AVSS3	AVSS4	NP	AF
AG	UART0_TX/GPIO4_C1	I2S_LRCK_RX/GPIO6_A1	I2S_SDO0/GPIO6_A4	I2S_SDO2/GPIO6_A6	EDP_TX0P	EDP_TX1P	EDP_TX2P	EDP_TX3P	EDP_AUXP	HDMI_TCP	AG
AH	SDIO0_D1/GPIO4_C5	UART0_RX/GPIO4_C0	I2S_SDO3/GPIO6_A7	I2S_SDO1/GPIO6_A5	EDP_TX0N	EDP_TX1N	EDP_TX2N	EDP_TX3N	EDP_AUXN	HDMI_TCN	AH
	10	11	12	13	14	15	16	17	18	19	

	20	21	22	23	24	25	26	27	28	
A	DDR0_DQ50	VSS9	HOST2_DM	HOST1_DM	NC/OTG_SUPER_RXM	NC/OTG_SUPER_TXM	OTG_DM	USIC_DATA	I2C1_SDA/SC_RST/GPI08_A4	A
B	DDR0_DQ50N	USB_AVSS4	HOST2_DP	HOST1_DP	NC/OTG_SUPER_RXP	NC/OTG_SUPER_TXP	OTG_DP	USIC_STROBE	SPI2_CS_N1/SC_IO/GPI08_A3	B
C	DDR0_DQ6	HOST2_TXRTUNE	NP	HOST1_TXRTUNE	USB_AVSS2	OTG_ID	USB_AVSS3	PS2_DATA/GPI08_A1	SPI2_TXD/SC_CLK_T1/GPI08_B1	C
D	DDR0_DQ7	OTG_TXRTUNE	NP	OTG_VBUS	PS2_CLK/GPI08_A0	NP	SPI2_CLK/SC_IO_T1/GPI08_A6	SPI2_CS_N0/SC_DET_T1/GPI08_A7	GPI07_A2	D
E	VSS7	USB_AVDD_1V8	BS_JTAG_TRSTN	BS_JTAG_TCK	NP	I2C1_SCL/SC_CLK/GPI08_A5	GPI07_A4	UART3_RX/GPS_MAG/HSADC_D0_T1/GPI07_A7	EDP_HOTPLUG/GPI07_B3	E
F	USB_AVDD_3V3	BS_JTAG_TDI	BS_JTAG_TDO	NP	SPI2_RXD/SC_RST_T1/GPI08_B0	GPI07_A3	GPI07_A6	UART3_RTSN/GPI07_B2	ISP_PRELIGHTTRIG/SPI1_RXD/GPI07_B6	F
G	BS_JTAG_TMS	GPI08_A2/SC_DET	NP	PWM1/GPI07_A1	GPI07_A5	NP	NP	ISP_SHUTTERTRIG/SPI1_TXD/GPI07_B7	ISP_FLASHTRIGIN/EDP_HDMI_CEC_T1/GPI07_C0	G
H	USIC_AVDD_1V2	NP	PWM0/GPI07_A0	UART3_CTSN/GPS_RFC_LK/GPS_CLK_T1/GPI07_B1	ISP_FLASHTRIGOUT/SPI1_CS_N0/GPI07_B5	I2C4_SDA/GPI07_C1	I2C5_SDA/EDPHDMI_I2C_SDA/GPI07_C3	GPI07_C5	UART2_TX/IR_TX/PWM3/EDPHDMI_CEC/GPI07_C7	H
J	APIO2_VDD	UART3_TX/GPS_SIG/HS_ADC_D1_T1/GPI07_B0	ISP_SHUTTEREN/SPI1_CLK/GPI07_B4	I2C4_SCL/GPI07_C2	I2C5_SCL/EDPHDMI_I2C_SCL/GPI07_C4	UART2_RX/IR_RX/PWM2/GPI07_C6	PMUGPI00_A2/DDRIO0_RETEN	PMUGPI00_A1/DDRIO0_PWROFF	PMUGPI00_A0/GLOBAL_PWROFF	J
K	NP	NP	NP	NP	NP	NP	NP	PMUGPI00_A3/DDRIO1_RETEN	PMUGPI00_A4	K
L	APIO1_VDD	PMUGPI00_A5	PMUGPI00_A6	PMUGPI00_A7	PMUGPI00_B0	PMUGPI00_B1	PMUGPI00_B2/OTP_OUT	PMUGPI00_B3	PMUGPI00_B5/CLK27M_IN	L
M	PMU_VDD_1V0	PMUGPI00_C0/I2C0_SCL	PMUGPI00_B6	PMUGPI00_C1/TEST_CLKOUT/CLK_27M_T1	PMUGPI00_C2	PMUGPI00_B7/I2C0_SDA	TEST	NPOR	PMUGPI00_B4	M
N	NP	NP	NP	NP	NP	NP	NP	OSC_XI	OSC_XO	N
P	PUMIO_VDD	ADC_IN1	I2C3_SCL/GPI02_C0	ADC_IN2	ADC_IN0	CLK32K	XVSS	PLL_AVSS	PLL_AVDD_1V0	P
R	ADC_AVDD_1V8	CIF_D11/GPI02_B7	CIF_CLKOUT/HOST_WKREQ/TS_FAIL/GPI02_B3	I2C3_SDA/GPI02_C1	CIF_D10/GPI02_B6	CIF_VSYNC/HOST_D6/TS_SYNC/GPI02_B0	CIF_D1/GPI02_B5	CIF_D0/GPI02_B4	CIF_HREF/HOST_D7/TS_VALID/GPI02_B1	R
T	NP	NP	NP	NP	NP	NP	NP	LCDC0_D0/LVDS_D0P/TRACE_D0	LCDC0_D1/LVDS_D0N/TRACE_D1	T
U	DVPIO_VDD	CIF_D7/HOST_CKINN/TS_D5/GPI02_A5	CIF_D6/HOST_CKINP/TS_D4/GPI02_A4	CIF_D8/HOST_D4/TS_D6/GPI02_A6	VSS8	LCDC0_D12/LVDS_D5P/TRACE_D12	LCDC0_D13/LVDS_D5N/TRACE_D13	LCDC0_D2/LVDS_D1P/TRACE_D2	LCDC0_D3/LVDS_D1N/TRACE_D3	U
V	LCDC_VDD	CIF_D5/HOST_D3/TS_D3/GPI02_A3	CIF_CLKIN/HOST_WKACK/GPS_CLK/TS_CLKOUT/GPI02_B2	CIF_D9/HOST_D5/TS_D7/GPI02_A7	LVDS_RBIAIS	LCDC0_D14/LVDS_D6P/TRACE_D14	LCDC0_D15/LVDS_D6N/TRACE_D15	LCDC0_D10/LVDS_CLKOP/TRACE_D10	LCDC0_D11/LVDS_CLKON/TRACE_D11	V
W	NP	NP	NP	NP	NP	NP	NP	LCDC0_D4/LVDS_D2P/TRACE_D4	LCDC0_D5/LVDS_D2N/TRACE_D5	W
Y	VSS63	CIF_D3/HOST_D1/TS_D1/GPI02_A1	CIF_D4/HOST_D2/TS_D2/GPI02_A2	CIF_D2/HOST_D0/TS_D0/GPI02_A0	VSS10	LCDC0_D22/LVDS_CLK1P	LCDC0_D23/LVDS_CLK1N	LCDC0_D6/LVDS_D3P/TRACE_D6	LCDC0_D7/LVDS_D3N/TRACE_D7	Y
AA	LVDS_AVDD_1V0	NP	LCDC0_DEN/GPI01_D2	LCDC0_HSYNC/GPI01_D0	LCDC0_DCLK/GPI01_D3	LCDC0_D16/LVDS_D7P/TRACE_CLK	LCDC0_D17/LVDS_D7N/TRACE_CTL	LCDC0_D8/LVDS_D4P/TRACE_D8	LCDC0_D9/LVDS_D4N/TRACE_D9	AA
AB	HDMI_AVDD_1V8	LVDS_AVDD_1V8	NP	LVDS_AVDD_3V3	LCDC0_VSYNC/GPI01_D1	NP	NP	LCDC0_D18/LVDS_D8P	LCDC0_D19/LVDS_D8N	AB
AC	MIPI_RX_AVDD_1V8	MIPI_TX/RX_AVDD_1V8	MIPI_TX_AVDD_1V8	NP	VSS11	LCDC0_D20/LVDS_D9P	LCDC0_D21/LVDS_D9N	MIPI_TX_D3P	MIPI_TX_D3N	AC
AD	AVSS5	MIPI_RX_REXT	MIPI_TX/RX_REXT	AVSS6	NP	MIPI_TX/RX_D3N	AVSS7	MIPI_TX_D2P	MIPI_TX_D2N	AD
AE	MIPI_TX/RX_D0P	MIPI_TX/RX_D1P	NP	MIPI_TX/RX_CLKP	MIPI_TX/RX_D2P	NP	MIPI_TX_REXT	MIPI_TX_CLKP	MIPI_TX_CLKN	AE
AF	MIPI_TX/RX_D0N	MIPI_TX/RX_D1N	NP	MIPI_TX/RX_CLKN	MIPI_TX/RX_D2N	MIPI_TX/RX_D3P	AVSS8	MIPI_TX_D1P	MIPI_TX_D1N	AF
AG	HDMI_TX0P	HDMI_TX1P	HDMI_TX2P	MIPI_RX_D0P	MIPI_RX_D1P	MIPI_RX_CLKP	MIPI_RX_D2P	MIPI_TX_D0P	MIPI_TX_D0N	AG
AH	HDMI_TX0N	HDMI_TX1N	HDMI_TX2N	MIPI_RX_D0N	MIPI_RX_D1N	MIPI_RX_CLKN	MIPI_RX_D2N	MIPI_RX_D3N	MIPI_RX_D3P	AH
	20	21	22	23	24	25	26	27	28	

Fig. 2-16 RK3288 Ball Mapping Diagram

2.5 Ball Pin Number Order

Table 2-1 RK3288 Ball Pin Number Order Information

A1	DDR0_DQ25	B1	DDR1_DQ24
A2	DDR0_DQ24	B2	DDR1_DQ25
A3	DDR0_DQ10	B3	DDR0_DM3
A4	DDR0_DQS3N	B4	DDR0_DQS3
A5	DDR0_DQ9	B5	DDR0_DQ8
A6	DDR0_DQ13	B6	DDR0_DQ14
A7	DDR0_DQS1N	B7	DDR0_DQS1
A8	DDR0_CASN	B8	DDR0_CS0N
A9	DDR0_BA1	B9	DDR0_WEN
A10	DDR0_A2	B10	DDR0_A0
A11	DDR0_CKN	B11	DDR0_CK
A12	DDR0_A7	B12	DDR0_A5
A13	DDR0_A10	B13	DDR0_A8
A14	DDR0_A9	B14	DDR0_A14
A15	DDR0_DM2	B15	DDR0_DQ16
A16	DDR0_DQ17	B16	DDR0_DQ19
A17	DDR0_DQS2N	B17	DDR0_DQS2
A18	DDR0_DQ23	B18	DDR0_DQ21
A19	DDR0_DQ4	B19	DDR0_DQ0
A20	DDR0_DQS0	B20	DDR0_DQS0N
A21	VSS	B21	USB_AVSS
A22	HOST2_DM	B22	HOST2_DP
A23	HOST1_DM	B23	HOST1_DP
A24	NC	B24	NC
A25	NC	B25	NC
A26	OTG_DM	B26	OTG_DP
A27	USIC_DATA	B27	USIC_STROBE
A28	I2C1_SDA/SC_RST/GPIO8_A4	B28	SPI2_CSN1/SC_IO/GPIO8_A3
C1	DDR1_DQ10	D1	DDR1_DQS3N
C2	DDR1_DQ30	D2	DDR1_DQS3
C3	VSS	D3	DDR1_DM3
C4	DDR0_DQ30	D4	NC
C5	DDR0_DQ28	D5	DDR0_DQ26
C6	DDR0_DQ11	D6	VSS
C7	NC	D7	NC
C8	DDR0_CKE1	D8	DDR0_BA0
C9	DDR0_CKE0	D9	VSS
C10	NC	D10	NC
C11	DDR0_A1	D11	DDR0_RASN
C12	DDR0_A6	D12	VSS
C13	NC	D13	NC

C14	DDR0_A13	D14	DDR0_A11
C15	DDR0_A15	D15	VSS
C16	NC	D16	NC
C17	DDR0_DQ22	D17	DDR0_DQ20
C18	DDR0_DQ1	D18	VSS
C19	NC	D19	NC
C20	DDR0_DQ6	D20	DDR0_DQ7
C21	HOST2_TXRTUNE	D21	OTG_TXRTUNE
C22	NC	D22	NC
C23	HOST1_TXRTUNE	D23	OTG_VBUS
C24	USB_AVSS	D24	PS2_CLK/GPIO8_A0
C25	OTG_ID	D25	NC
C26	USB_AVSS	D26	SPI2_CLK/SC_IO_T1/GPIO8_A6
C27	PS2_DATA/GPIO8_A1	D27	SPI2_CSN0/SC_DET_T1/GPIO8_A7
C28	SPI2_TXD/SC_CLK_T1/GPIO8_B1	D28	GPIO7_A2
E1	DDR1_DQ9	F1	DDR1_CKE0
E2	DDR1_DQ8	F2	DDR1_RESET
E3	DDR1_DQ28	F3	DDR1_DQ11
E4	DDR1_DQ26	F4	VSS
E5	NC	F5	DDR1_DQ29
E6	DDR0_DQ27	F6	NC
E7	DDR0_DQ31	F7	DDR0_DQ29
E8	DDR0_DQ12	F8	DDR0_DQ15
E9	DDR0_RESET	F9	DDR0_DM1
E10	NC	F10	NC
E11	DDR0_BA2	F11	DDR0_CS1N
E12	DDR0_A3	F12	DDR0_A4
E13	NC	F13	NC
E14	DDR0_ODT0	F14	DDR0_A12
E15	DDR0_ODT1	F15	DDR0_DQ18
E16	NC	F16	NC
E17	DDR0_DM0	F17	DDR0_DQ2
E18	DDR0_DQ5	F18	DDR0_DQ3
E19	NC	F19	NC
E20	VSS	F20	USB_AVDD_3V3
E21	USB_AVDD_1V8	F21	BS_JTAG_TDI
E22	BS_JTAG_TRSTN	F22	BS_JTAG_TDO
E23	BS_JTAG_TCK	F23	NC
E24	NC	F24	SPI2_RXD/SC_RST_T1/GPIO8_B0
E25	I2C1_SCL/SC_CLK/GPIO8_A5	F25	GPIO7_A3
E26	GPIO7_A4	F26	GPIO7_A6
E27	UART3_RX/GPS_MAG/HSADC_D0_T1/ GPIO7_A7	F27	UART3_RTSN/GPIO7_B2
E28	EDP_HOTPLUG/GPIO7_B3	F28	ISP_PRELIGHTTRIG/SPI1_RXD/GPIO 7_B6

G1	DDR1_DQS1N	H1	DDR1_CASN
G2	DDR1_DQS1	H2	DDR1_CS0N
G3	NC	H3	DDR1_CKE1
G4	NC	H4	DDR1_DQ13
G5	DDR1_DM1	H5	DDR1_DQ12
G6	DDR1_DQ27	H6	DDR1_DQ31
G7	NC	H7	DDR1_RETLE
G8	DDR0_RETLE	H8	NC
G9	NC	H9	DDR0_VDD
G10	NC	H10	NC
G11	NC	H11	DDR0_VREFAO
G12	DDR0_ATO	H12	DDR0_VREF
G13	NC	H13	NC
G14	NC	H14	DDR0_VDDAO
G15	NC	H15	DDR0.DTO1
G16	NC	H16	NC
G17	DDR0_PZQ	H17	DDR0.DTO0
G18	USB_AVDD_1V0	H18	USB_AVSS
G19	NC	H19	NC
G20	BS_JTAG_TMS	H20	USIC_AVDD_1V2
G21	GPIO8_A2/SC_DET	H21	NC
G22	NC	H22	PWM0/GPIO7_A0
G23	PWM1/GPIO7_A1	H23	UART3_CTSN/GPS_RFCLK/GPS_CLK_T1/GPIO7_B1
G24	GPIO7_A5	H24	ISP_FLASHTRIGOUT/SPI1_CSN0/GPIO7_B5
G25	NC	H25	I2C4_SDA/GPIO7_C1
G26	NC	H26	I2C5_SDA/EDPHDMI_I2C_SDA/GPIO7_C3
G27	ISP_SHUTTERTRIG/SPI1_TXD/GPIO7_B7	H27	GPIO7_C5
G28	ISP_FLASHTRIGIN/EDPHDMI_CEC_T1/GPIO7_C0	H28	UART2_TX/IR_TX/PWM3/EDPHDMI_CEC/GPIO7_C7
J1	DDR1_BA1	K1	DDR1_A2
J2	DDR1_WEN	K2	DDR1_A1
J3	DDR1_CS1N	K3	NC
J4	VSS	K4	NC
J5	DDR1_DQ14	K5	NC
J6	DDR1_DQ15	K6	NC
J7	NC	K7	NC
J8	DDR1_VDD	K8	NC
J9	VSS	K9	NC
J10	NC	K10	VSS
J11	DDR0_VDD	K11	VSS
J12	DDR0_VDD	K12	VSS

J13	NC	K13	VSS
J14	DDR0_VDD	K14	VSS
J15	DDR0_VDD	K15	VSS
J16	NC	K16	VSS
J17	VSS	K17	VSS
J18	VSS	K18	VSS
J19	NC	K19	VSS
J20	APIO2_VDD	K20	NC
J21	UART3_TX/GPS_SIG/HSADC_D1_T1/GPIO7_B0	K21	NC
J22	ISP_SHUTTEREN/SPI1_CLK/GPIO7_B4	K22	NC
J23	I2C4_SCL/GPIO7_C2	K23	NC
J24	I2C5_SCL/EDPHDMI_I2C_SCL/GPIO7_C4	K24	NC
J25	UART2_RX/IR_RX/PWM2/GPIO7_C6	K25	NC
J26	PMUGPIO0_A2/DDRIO0_RETEN	K26	NC
J27	PMUGPIO0_A1/DDRIO_PWROFF	K27	PMUGPIO0_A3/DDRIO1_RETEN
J28	PMUGPIO0_A0/GLOBAL_PWROFF	K28	PMUGPIO0_A4
L1	DDR1_CKN	M1	DDR1_A6
L2	DDR1_CK	M2	DDR1_A5
L3	DDR1_A0	M3	DDR1_A7
L4	DDR1_BA0	M4	VSS
L5	DDR1_BA2	M5	DDR1_A3
L6	DDR1_RASN	M6	DDR1_A4
L7	NC	M7	DDR1_ATO
L8	DDR1_VREFAO	M8	DDR1_VREF
L9	DDR1_VDD	M9	DDR1_VDD
L10	VSS	M10	VSS
L11	VSS	M11	VSS
L12	LOGIC_VDD	M12	LOGIC_VDD
L13	VSS	M13	VSS
L14	VSS	M14	VSS
L15	VSS	M15	GPU_VDD
L16	GPU_VDD	M16	GPU_VDD
L17	GPU_VDD	M17	GPU_VDD
L18	GPU_VDD	M18	GPU_VDD
L19	GPU_VDD	M19	GPU_VDD
L20	APIO1_VDD	M20	PMU_VDD_1V0
L21	PMUGPIO0_A5	M21	PMUGPIO0_C0/I2C0_SCL
L22	PMUGPIO0_A6	M22	PMUGPIO0_B6
L23	PMUGPIO0_A7	M23	PMUGPIO0_C1/TEST_CLKOUT/CLK_27M_T1
L24	PMUGPIO0_B0	M24	PMUGPIO0_C2
L25	PMUGPIO0_B1	M25	PMUGPIO0_B7/I2C0_SDA
L26	PMUGPIO0_B2/OTP_OUT	M26	TEST

L27	PMUGPIO0_B3	M27	NPOR
L28	PMUGPIO0_B5/CLK27M_IN	M28	PMUGPIO0_B4
N1	DDR1_A8	P1	DDR1_A9
N2	DDR1_A10	P2	DDR1_A14
N3	NC	P3	DDR1_A13
N4	NC	P4	DDR1_A11
N5	NC	P5	DDR1_ODT0
N6	NC	P6	DDR1_A12
N7	NC	P7	NC
N8	NC	P8	DDR1_VDDAO
N9	NC	P9	DDR1_VDD
N10	VSS	P10	VSS
N11	VSS	P11	VSS
N12	LOGIC_VDD	P12	LOGIC_VDD
N13	VSS	P13	VSS
N14	VSS	P14	VSS
N15	VSS	P15	VSS
N16	GPU_VDD	P16	VSS
N17	GPU_VDD	P17	VSS
N18	GPU_VDD	P18	VSS
N19	GPU_VDD	P19	EFUSE_VQPS
N20	NC	P20	PUMIO_VDD
N21	NC	P21	ADC_IN1
N22	NC	P22	I2C3_SCL/GPIO2_C0
N23	NC	P23	ADC_IN2
N24	NC	P24	ADC_IN0
N25	NC	P25	CLK32K
N26	NC	P26	VSS
N27	OSC_XI	P27	PLL_AVSS
N28	OSC_XO	P28	PLL_AVDD_1V0
R1	DDR1_A15	T1	DDR1_DQ18
R2	DDR1_ODT1	T2	DDR1_DQ16
R3	DDR1_DM2	T3	NC
R4	VSS	T4	NC
R5	DDR1_DQ19	T5	NC
R6	DDR1_DQ17	T6	NC
R7	NC	T7	NC
R8	DDR1_DTO1	T8	NC
R9	DDR1_VDD	T9	NC
R10	VSS	T10	VSS
R11	LOGIC_VDD	T11	LOGIC_VDD
R12	LOGIC_VDD	T12	LOGIC_VDD
R13	VSS	T13	VSS
R14	VSS	T14	CPU_VDD
R15	VSS	T15	VSS

R16	VSS	T16	VSS
R17	VSS	T17	VSS
R18	VSS	T18	VSS
R19	VSS	T19	VSS
R20	ADC_AVDD_1V8	T20	NC
R21	CIF_D11/GPIO2_B7	T21	NC
R22	CIF_CLKOUT/HOST_WKREQ/TS_FAIL/ GPIO2_B3	T22	NC
R23	I2C3_SDA/GPIO2_C1	T23	NC
R24	CIF_D10/GPIO2_B6	T24	NC
R25	CIF_VSYNC/HOST_D6/TS_SYNC/GPIO 2_B0	T25	NC
R26	CIF_D1/GPIO2_B5	T26	NC
R27	CIF_D0/GPIO2_B4	T27	LCDC0_D0/LVDS_D0P/TRACE_D0
R28	CIF_HREF/HOST_D7/TS_VALID/GPIO2 _B1	T28	LCDC0_D1/LVDS_D0N/TRACE_D1
U1	DDR1_DQS2N	V1	DDR1_DQ21
U2	DDR1_DQS2	V2	DDR1_DQ23
U3	DDR1_DQ22	V3	DDR1_DQ1
U4	DDR1_DQ20	V4	VSS
U5	DDR1_DM0	V5	DDR1_DQ6
U6	DDR1_DQ3	V6	FLASH1_D1/HOST_D1/MAC_TXD3/S DIO1_D1/GPIO3_D1
U7	DDR1_PZQ	V7	FLASH1_CSN2/HOST_D15/MAC_TXCL K/SDIO1_PWREN/GPIO4_B1
U8	DDR1_DT00	V8	FLASH1_VDD
U9	VSS	V9	VSS
U10	VSS	V10	VSS
U11	LOGIC_VDD	V11	VSS
U12	LOGIC_VDD	V12	VSS
U13	VSS	V13	VSS
U14	CPU_VDD	V14	CPU_VDD
U15	CPU_VDD	V15	CPU_VDD
U16	CPU_VDD	V16	CPU_VDD
U17	CPU_VDD	V17	CPU_VDD
U18	CPU_VDD	V18	CPU_VDD
U19	CPU_VDD	V19	CPU_VDD
U20	DVPIO_VDD	V20	LCDC_VDD
U21	CIF_D7/HOST_CKINN/TS_D5/GPIO2_A 5	V21	CIF_D5/HOST_D3/TS_D3/GPIO2_A3
U22	CIF_D6/HOST_CKINP/TS_D4/GPIO2_A 4	V22	CIF_CLKIN/HOST_WKACK/GPS_CLK/ TS_CLKOUT/GPIO2_B2
U23	CIF_D8/HOST_D4/TS_D6/GPIO2_A6	V23	CIF_D9/HOST_D5/TS_D7/GPIO2_A7
U24	VSS	V24	LVDS_RBIAS
U25	LCDC0_D12/LVDS_D5P/TRACE_D12	V25	LCDC0_D14/LVDS_D6P/TRACE_D14

U26	LCDC0_D13/LVDS_D5N/TRACE_D13	V26	LCDC0_D15/LVDS_D6N/TRACE_D15
U27	LCDC0_D2/LVDS_D1P/TRACE_D2	V27	LCDC0_D10/LVDS_CLK0P/TRACE_D10
U28	LCDC0_D3/LVDS_D1N/TRACE_D3	V28	LCDC0_D11/LVDS_CLK0N/TRACE_D11
W1	DDR1_DQ4	Y1	DDR1_DQ2
W2	DDR1_DQ0	Y2	DDR1_DQ5
W3	NC	Y3	DDR1_DQ7
W4	NC	Y4	FLASH1_D0/HOST_D0/MAC_TXD2/S DIO1_D0/GPIO3_D0
W5	NC	Y5	FLASH1_WRN/HOST_D11/MAC_CMD/ GPIO4_A5
W6	NC	Y6	FLASH0_RDN/GPIO3_B2
W7	NC	Y7	FLASH0_CSN3/EMMC_RSTNOUT/GPI O3_C1
W8	NC	Y8	GPIO3_C3/FLASH0_VOLTAGE_SEL
W9	NC	Y9	FLASH0_VDD
W10	VSS	Y10	NC
W11	VSS	Y11	APIO5_VDD
W12	VSS	Y12	APIO4_VDD
W13	VSS	Y13	NC
W14	VSS	Y14	NC
W15	VSS	Y15	NC
W16	VSS	Y16	NC
W17	VSS	Y17	EDP_AVDD_1V0
W18	VSS	Y18	VSS
W19	VSS	Y19	NC
W20	NC	Y20	VSS
W21	NC	Y21	CIF_D3/HOST_D1/TS_D1/GPIO2_A1
W22	NC	Y22	CIF_D4/HOST_D2/TS_D2/GPIO2_A2
W23	NC	Y23	CIF_D2/HOST_D0/TS_D0/GPIO2_A0
W24	NC	Y24	VSS
W25	NC	Y25	LCDC0_D22/LVDS_CLK1P
W26	NC	Y26	LCDC0_D23/LVDS_CLK1N
W27	LCDC0_D4/LVDS_D2P/TRACE_D4	Y27	LCDC0_D6/LVDS_D3P/TRACE_D6
W28	LCDC0_D5/LVDS_D2N/TRACE_D5	Y28	LCDC0_D7/LVDS_D3N/TRACE_D7
AA1	DDR1_DQS0N	AB1	FLASH1_D2/HOST_D2/MAC_RXD2/S DIO1_D2/GPIO3_D2
AA2	DDR1_DQS0	AB2	FLASH1_D5/HOST_D5/MAC_TXD1/S DIO1_WRPRT/GPIO3_D5
AA3	FLASH1_D6/HOST_D6/MAC_RXD0/SDI O1_BKPWR/GPIO3_D6	AB3	NC
AA4	FLASH1_D7/HOST_D7/MAC_RXD1/SDI O1_INTN/GPIO3_D7	AB4	NC

AA5	FLASH1_DQS/HOST_D14/MAC_COL/FLASH1__CSN3/GPIO4_B0	AB5	FLASH1_CSN0/HOST_D12/MAC_RXCLK/SDIO1_CMD/GPIO4_A6
AA6	FLASH1_CSN1/HOST_D13/MAC_CRSDIO1_CLKOUT/GPIO4_A7	AB6	FLASH0_DQS/EMMC_CLKOUT/GPIO3_C2
AA7	UART1_TX/TS0_D1/GPIO5_B1	AB7	NC
AA8	NC	AB8	TS0_ERR/GPIO5_C3
AA9	TS0_VALID/GPIO5_C1	AB9	SDMMC0_D3/JTAG_TCK/GPIO6_C3
AA10	NC	AB10	NC
AA11	APIO3_VDD	AB11	UART0_RTSN/GPIO4_C3
AA12	EDP_TP_OUT/SATA_REXT	AB12	UART0_CTSN/GPIO4_C2
AA13	NC	AB13	NC
AA14	NC	AB14	NC
AA15	NC	AB15	NC
AA16	NC	AB16	NC
AA17	EDP_AVDD_1V8	AB17	HDMI_REXT
AA18	HDMI_AVDD_1V0	AB18	HDMI_HPD
AA19	NC	AB19	NC
AA20	LVDS_AVDD_1V0	AB20	HDMI_AVDD_1V8
AA21	NC	AB21	LVDS_AVDD_1V8
AA22	LCDC0_DEN/GPIO1_D2	AB22	NC
AA23	LCDC0_HSYNC/GPIO1_D0	AB23	LVDS_AVDD_3V3
AA24	LCDC0_DCLK/GPIO1_D3	AB24	LCDC0_VSYNC/GPIO1_D1
AA25	LCDC0_D16/LVDS_D7P/TRACE_CLK	AB25	NC
AA26	LCDC0_D17/LVDS_D7N/TRACE_CTL	AB26	NC
AA27	LCDC0_D8/LVDS_D4P/TRACE_D8	AB27	LCDC0_D18/LVDS_D8P
AA28	LCDC0_D9/LVDS_D4N/TRACE_D9	AB28	LCDC0_D19/LVDS_D8N
AC1	FLASH1_D3/HOST_D3/MAC_RXD3/SDIO1_D3/GPIO3_D3	AD1	FLASH1_D4/HOST_D4/MAC_TXD0/SDIO1_DET/GPIO3_D4
AC2	FLASH1_WP/HOST_CKOUTN/MAC_RXDV/FLASH0_CSN4/GPIO4_A1	AD2	FLASH1_CLE/HOST_D10/MAC_TXEN/FLASH0_CSN7/GPIO4_A4
AC3	FLASH1_RDY/HOST_CKOUTP/MAC_MD C/GPIO4_A0	AD3	FLASH0_D1/EMMC_D1/GPIO3_A1
AC4	FLASH0_CSN2/EMMC_CMD/GPIO3_C0	AD4	FLASH0_CSN1/GPIO3_B7
AC5	FLASH0_CSN0/GPIO3_B6	AD5	NC
AC6	NC	AD6	UART1_RTSN/TS0_D3/GPIO5_B3
AC7	SPI0_CSN0/TS0_D5/UART4_RTSN/GPIO5_B5	AD7	SPI0_CLK/TS0_D4/UART4_CTSN/GPIO5_B4
AC8	SDMMC0_CMD/GPIO6_C5	AD8	SDMMC0_D2/JTAG_TDI/GPIO6_C2
AC9	SDMMC0_VDD	AD9	GPIO4_D7
AC10	NC	AD10	NC
AC11	SDIO0_PWREN/GPIO4_D4	AD11	I2S_SCLK/GPIO6_A0
AC12	I2S_CLK/GPIO6_B0	AD12	I2C2_SCL/GPIO6_B2
AC13	NC	AD13	NC
AC14	NC	AD14	NC
AC15	NC	AD15	NC

AC16	NC	AD16	NC
AC17	EDP_CLK24M_IN/MIPI_LLI_REXT	AD17	NC
AC18	EDP_REXT	AD18	NC
AC19	NC	AD19	NC
AC20	MIPI_RX_AVDD_1V8	AD20	AVSS
AC21	MIPI_TX/RX_AVDD_1V8	AD21	MIPI_RX_REXT
AC22	MIPI_TX_AVDD_1V8	AD22	MIPI_TX/RX_REXT
AC23	NC	AD23	AVSS
AC24	VSS	AD24	NC
AC25	LCDC0_D20/LVDS_D9P	AD25	MIPI_TX/RX_D3N
AC26	LCDC0_D21/LVDS_D9N	AD26	AVSS
AC27	MIPI_TX_D3P	AD27	MIPI_TX_D2P
AC28	MIPI_TX_D3N	AD28	MIPI_TX_D2N
AE1	FLASH1_RDN/HOST_D8/MAC_RXER/FLASH0_CSN5/GPIO4_A2	AF1	FLASH0_D3/EMMC_D3/GPIO3_A3
AE2	FLASH1_ALE/HOST_D9/MAC_CLK/FLASH0_CSN6/GPIO4_A3	AF2	FLASH0_D4/EMMC_D4/GPIO3_A4
AE3	FLASH0_D0/EMMC_D0/GPIO3_A0	AF3	FLASH0_D2/EMMC_D2/GPIO3_A2
AE4	NC	AF4	FLASH0_ALE/GPIO3_B3
AE5	SPI0_TXD/TS0_D6/UART4_TX/GPIO5_B6	AF5	UART1_RX/TS0_D0/GPIO5_B0
AE6	TS0_CLK/GPIO5_C2	AF6	SPI0_RXD/TS0_D7/UART4_RX/GPIO5_B7
AE7	NC	AF7	NC
AE8	SDIO0_INTN/GPIO4_D6	AF8	SDIO0_BKPWR/GPIO4_D5
AE9	SDIO0_WRPRT/GPIO4_D3	AF9	SDIO0_DET/GPIO4_D2
AE10	NC	AF10	NC
AE11	I2S_SDI/GPIO6_A3	AF11	I2S_LRCK_TX/GPIO6_A2
AE12	SPDIF_TX/GPIO6_B3	AF12	I2C2_SDA/GPIO6_B1
AE13	NC	AF13	NC
AE14	NC	AF14	AVSS
AE15	NC	AF15	AVSS
AE16	NC	AF16	NC
AE17	NC	AF17	AVSS
AE18	NC	AF18	AVSS
AE19	NC	AF19	NC
AE20	MIPI_TX/RX_D0P	AF20	MIPI_TX/RX_D0N
AE21	MIPI_TX/RX_D1P	AF21	MIPI_TX/RX_D1N
AE22	NC	AF22	NC
AE23	MIPI_TX/RX_CLKP	AF23	MIPI_TX/RX_CLKN
AE24	MIPI_TX/RX_D2P	AF24	MIPI_TX/RX_D2N
AE25	NC	AF25	MIPI_TX/RX_D3P
AE26	MIPI_TX_REXT	AF26	AVSS
AE27	MIPI_TX_CLKP	AF27	MIPI_TX_D1P
AE28	MIPI_TX_CLKN	AF28	MIPI_TX_D1N

AG1	FLASH0_D6/EMMC_D6/GPIO3_A6	AH1	FLASH0_WP/EMMC_PWREN/GPIO3_B1
AG2	FLASH0_D7/EMMC_D7/GPIO3_A7	AH2	FLASH0_RDY/GPIO3_B0
AG3	FLASH0_D5/EMMC_D5/GPIO3_A5	AH3	FLASH0_CLE/GPIO3_B4
AG4	FLASH0_WRN/GPIO3_B5	AH4	UART1_CTSN/TS0_D2/GPIO5_B2
AG5	SPI0_CSN1/TS0_SYNC/GPIO5_C0	AH5	SDMMC0_DECTN/GPIO6_C6
AG6	SDMMC0_CLKOUT/JTAG_TDO/GPIO6_C4	AH6	SDMMC0_D1/JTAG_TRSTN/GPIO6_C1
AG7	SDMMC0_D0/JTAG_TMS/GPIO6_C0	AH7	SDIO0_D3/GPIO4_C7
AG8	SDIO0_CLKOUT/GPIO4_D1	AH8	SDIO0_CMD/GPIO4_D0
AG9	SDIO0_D2/GPIO4_C6	AH9	SDIO0_D0/GPIO4_C4
AG10	UART0_TX/GPIO4_C1	AH10	SDIO0_D1/GPIO4_C5
AG11	I2S_LRCK_RX/GPIO6_A1	AH11	UART0_RX/GPIO4_C0
AG12	I2S_SDO0/GPIO6_A4	AH12	I2S_SDO3/GPIO6_A7
AG13	I2S_SDO2/GPIO6_A6	AH13	I2S_SDO1/GPIO6_A5
AG14	EDP_TX0P	AH14	EDP_TX0N
AG15	EDP_TX1P	AH15	EDP_TX1N
AG16	EDP_TX2P	AH16	EDP_TX2N
AG17	EDP_TX3P	AH17	EDP_TX3N
AG18	EDP_AUXP	AH18	EDP_AUXN
AG19	HDMI_TCP	AH19	HDMI_TCN
AG20	HDMI_TX0P	AH20	HDMI_TX0N
AG21	HDMI_TX1P	AH21	HDMI_TX1N
AG22	HDMI_TX2P	AH22	HDMI_TX2N
AG23	MIPI_RX_D0P	AH23	MIPI_RX_D0N
AG24	MIPI_RX_D1P	AH24	MIPI_RX_D1N
AG25	MIPI_RX_CLKP	AH25	MIPI_RX_CLKN
AG26	MIPI_RX_D2P	AH26	MIPI_RX_D2N
AG27	MIPI_TX_D0P	AH27	MIPI_RX_D3N
AG28	MIPI_TX_D0N	AH28	MIPI_RX_D3P

2.6 Power/ground IO descriptions

Table 2-2 RK3288 Power/Ground IO information

Group	Ball #	Descriptions
VSS	C3,D6,D9,D12,D15,D18,E20,U24,A21,Y24,AC24,F4,J4,J9,U9,J17,W10,K10,K11,K12,K13,K14,K15,K16,K17,K18,K19,J18,L10,L11,L13,L14,L15,M4,M10,M11,M13,M14,Y18,N10,N11,N13,N14,N15,P10,P11,P13,P14,P15,P16,P17,P18,R4,R10,R13,R16,R17,R18,R19,T10,R14,T13,Y20,T15,T16,T17,T18,T19,V9,U10,R15,U13,V4,V10,V11,V12,V13,W11,W12,W13,W14,W15,W16,W17,W18,W19,P26	Internal Logic Ground and Digital IO Ground
CPU_VDD	U14,U15,U16,U17,U18,U19,V14,V15,V16,V17,V18,V19,T14	Internal CPU core Power
LOGIC_VDD	L12,M12,N12,P12,R12,T12,U12,R11,T11,U11	Internal Logic core Power Supply

Group	Ball #	Descriptions
GPU_VDD	M15,L16,L17,L18,L19,N16,N17,M16,M17,M18,M19,N18,N19	Internal GPU core Power Supply
DDR0_VDDAO	H14	DDR3 Digital IO Power Supply LPDDR2/3 Digital IO Power Supply
DDR1_VDDAO	P8	DDR3 Digital IO Power Supply LPDDR2/3 Digital IO Power Supply
DDR0_VDD	H9,J11,J12,J14,J15	DDR3 Digital IO Power Supply LPDDR2/3 Digital IO Power Supply
DDR1_VDD	J8,L9,M9,P9,R9	DDR3 Digital IO Power Supply LPDDR2/3 Digital IO Power Supply
PMU_VDD_1V0	M20	Internal PMU Domain Logic Power Supply
PMUIO_VDD	P20	PMU Domain Digital IO Power Supply
APIO1_VDD	L20	GPIO30 Digital IO Power Supply
APIO2_VDD	J20	GPIO1830 Digital IO Power Supply
LCDC_VDD	V20	LCDC Digital IO Power Supply
DVPIO_VDD	U20	DVP Digital IO Power Supply
FLASH0_VDD	Y9	Nand Flash0 Digital IO Power Supply
FLASH1_VDD	V8	Nand Flash1 Digital IO Power Supply
SDMMC0_VDD	AC9	SDMMC0 Digital IO Power Supply
APIO3_VDD	AA11	WIFI Digital IO Power Supply
APIO4_VDD	Y12	AUDIO Digital IO Power Supply
APIO5_VDD	Y11	BB Digital IO Power Supply
PLL_AVSS	P27	PLL Analog Ground
PLL_AVDD_1V0	P28	PLL Analog Power Supply
ADC_AVDD_1V8	R20	SAR-ADC/TSADC Analog Power Supply
USB_AVDD_1V0	G18	USB OTG2.0/Host2.0 Digital Power Supply
USB_AVDD_1V8	E21	USB OTG2.0/Host2.0 Analog Power Supply
USB_AVDD_3V3	F20	USB OTG2.0/Host2.0 Analog Power Supply
USB_AVSS	H18,C24,C26,B21	USB Analog Ground
EFUSE_VDDQ	P19	eFuse IO Digital Power Supply
USIC_VDD_1V2	H20	USIC 1.2V Transmitter Power Supply
EDP_AVDD_1V0	Y17	eDP 1.0V Power Supply
EDP_AVDD_1V8	AA17	eDP 1.8V Power Supply
HDMI_AVDD_1V0	AA18	HDMI 1.0V Power Supply

Group	Ball #	Descriptions
HDMI_AVDD_1V8	AB20	HDMI 1.8V Power Supply
LVDS_AVDD_1V0	AA20	LVDS 1.0V Power Supply
LVDS_AVDD_1V8	AB21	LVDS 1.8V Power Supply
LVDS_AVDD_3V3	AB23	LVDS 3.3V Power Supply
MIPI_TXRX_AVDD_1V8	AC21	MIPI TX/RX PHY 1.8V Power Supply
MIPI_TX_AVDD_1V8	AC22	MIPI TX PHY 1.8V Power Supply
MIPI_RX_AVDD_1V8	AC20	MIPI RX PHY 1.8V Power Supply

2.7 Function IO description

Pad#	Ball#	func0	func1	func2	func3	func4	Pad type	Curr ent	Pull	Reset State	Power Supply
NPOR	M27	npor					I	2	up	I	PMU
XIN24M	N27	xin24m					I	2	NA	I	
XOUT24M	N28	xout24m					O	2	NA	O	
TEST	M26	test					I	8	down	I	
CLK32K	P25	clk32k					I/O	8	down	I	
PMUGPIO0_A0/GLOBAL_PWROFF	J28	gpio0a0	global_pwroff				I/O	8	down	I	
PMUGPIO0_A1/DDRIO_PWROFF	J27	gpio0a1	ddrio_pwroff				I/O	8	down	I	
PMUGPIO0_A2/DDRIO0_RETEN	J26	gpio0a2	ddrio0_reten				I/O	4	up	I	
PMUGPIO0_A3/DDRIO1_RETEN	K27	gpio0a3	ddrio1_reten				I/O	4	up	I	
PMUGPIO0_A4	K28	gpio0a4					I/O	2	up	I	
PMUGPIO0_A5	L21	gpio0a5					I/O	2	up	I	
PMUGPIO0_A6	L22	gpio0a6					I/O	2	up	I	
PMUGPIO0_A7	L23	gpio0a7					I/O	2	up	I	
PMUGPIO0_B0	L24	gpio0b0					I/O	2	up	I	
PMUGPIO0_B1	L25	gpio0b1					I/O	2	up	I	
PMUGPIO0_B2/OTP_OUT	L26	gpio0b2	tsadc_int				I/O	2	down	I	
PMUGPIO0_B3	L27	gpio0b3					I/O	2	down	I	
PMUGPIO0_B4	M28	gpio0b4					I/O	2	down	I	
PMUGPIO0_B5/CLK27M_IN	L28	gpio0b5	clk_27m				I/O	2	down	I	
PMUGPIO0_B6	M22	gpio0b6					I/O	2	down	I	
PMUGPIO0_B7/I2C0_SDA	M25	gpio0b7	i2c0pmu_sda				I/O	2	up	I	
PMUGPIO0_C0/I2C0_SCL	M21	gpio0c0	i2c0pmu_scl				I/O	2	up	I	
PMUGPIO0_C1/TEST_CLKOUT/CLK_27M_T1	M23	gpio0c1	test_clkout	clkt1_27m			I/O	4	down	I	
PMUGPIO0_C2	M24	gpio0c2					I/O	2	up	I	
LCDC0_HSYNC/GPIO1_D0	AA23	gpio1d0	lcdc0_hsync				I/O	8	down	I	LCDC
LCDC0_VSYNC/GPIO1_D1	AB24	gpio1d1	lcdc0_vsync				I/O	8	down	I	
LCDC0_DEN/GPIO1_D2	AA22	gpio1d2	lcdc0_den				I/O	8	down	I	
LCDC0_DCLK/GPIO1_D3	AA24	gpio1d3	lcdc0_dclk				I/O	8	down	I	
CIF_D2/HOST_D0/TS_D0/GPIO2_A0	Y23	gpio2a0	cif_data2	host_din0	hsadc_data0		I/O	8	down	I	DVP
CIF_D3/HOST_D1/TS_D1/GPIO2_A1	Y21	gpio2a1	cif_data3	host_din1	hsadc_data1		I/O	8	down	I	
CIF_D4/HOST_D2/TS_D2/GPIO2_A2	Y22	gpio2a2	cif_data4	host_din2	H sadc_data2		I/O	8	down	I	
CIF_D5/HOST_D3/TS_D3/GPIO2_A3	V21	gpio2a3	cif_data5	host_din3	hsadc_data3		I/O	8	down	I	
CIF_D6/HOST_CKINP/TS_D4/GPIO2_A4	U22	gpio2a4	cif_data6	host_ckinp	hsadc_data4		I/O	8	down	I	

Pad#	Ball#	func0	func1	func2	func3	func4	Pad type	Current	Pull	Reset State	Power Supply
CIF_D7/HOST_CKINN/TS_D5/GPIO2_A5	U21	gpio2a5	cif_data7	host_ckinn	hsadc_data5		I/O	8	down	I	
CIF_D8/HOST_D4/TS_D6/GPIO2_A6	U23	gpio2a6	cif_data8	host_din4	hsadc_data6		I/O	8	down	I	
CIF_D9/HOST_D5/TS_D7/GPIO2_A7	V23	gpio2a7	cif_data9	host_din5	hsadc_data7		I/O	8	down	I	
CIF_VSYNC/HOST_D6/TS_SYNC/GPIO2_B0	R25	gpio2b0	cif_vsync	host_din6	hsadcts_sync		I/O	8	down	I	
CIF_HREF/HOST_D7/TS_VALID/GPIO2_B1	R28	gpio2b1	cif_href	host_din7	hsadcts_valid		I/O	8	down	I	
CIF_CLKIN/HOST_WKACK/GPS_CLK/TS_CLKOUT/GPIO2_B2	V22	gpio2b2	cif_clk	host_wkack	gps_clk	hsadc_clkout	I/O	8	down	I	
CIF_CLKOUT/HOST_WKREQ/TS_FAIL/GPIO2_B3	R22	gpio2b3	cif_clkout	host_wkreq	hsadcts_fail		I/O	8	down	I	
CIF_D0/GPIO2_B4	R27	gpio2b4	cif_data0				I/O	8	down	I	
CIF_D1/GPIO2_B5	R26	gpio2b5	cif_data1				I/O	8	down	I	
CIF_D10/GPIO2_B6	R24	gpio2b6	cif_data10				I/O	8	down	I	
CIF_D11/GPIO2_B7	R21	gpio2b7	cif_data11				I/O	8	down	I	
I2C3_SCL/GPIO2_C0	P22	gpio2c0	i2c3cam_scl				I/O	2	up	I	
I2C3_SDA/GPIO2_C1	R23	gpio2c1	i2c3cam_sda				I/O	2	up	I	
FLASH0_D0/EMMC_D0/GPIO3_A0	AE3	gpio3a0	flash0_data0	emmc_data0			I/O	8	up	I	FLASH0
FLASH0_D1/EMMC_D1/GPIO3_A1	AD3	gpio3a1	flash0_data1	emmc_data1			I/O	8	up	I	
FLASH0_D2/EMMC_D2/GPIO3_A2	AF3	gpio3a2	flash0_data2	emmc_data2			I/O	8	up	I	
FLASH0_D3/EMMC_D3/GPIO3_A3	AF1	gpio3a3	flash0_data3	emmc_data3			I/O	8	up	I	
FLASH0_D4/EMMC_D4/GPIO3_A4	AF2	gpio3a4	flash0_data4	emmc_data4			I/O	8	up	I	
FLASH0_D5/EMMC_D5/GPIO3_A5	AG3	gpio3a5	flash0_data5	emmc_data5			I/O	8	up	I	
FLASH0_D6/EMMC_D6/GPIO3_A6	AG1	gpio3a6	flash0_data6	emmc_data6			I/O	8	up	I	
FLASH0_D7/EMMC_D7/GPIO3_A7	AG2	gpio3a7	flash0_data7	emmc_data7			I/O	8	up	I	
FLASH0_RDY/GPIO3_B0	AH2	gpio3b0	flash0_rdy				I/O	4	up	I	
FLASH0_WP/EMMC_PWREN/GPIO3_B1	AH1	gpio3b1	flash0_wp	emmc_pwren			I/O	4	down	I	
FLASH0_RDN/GPIO3_B2	Y6	gpio3b2	flash0_rdn				I/O	4	up	I	
FLASH0_ALE/GPIO3_B3	AF4	gpio3b3	flash0_ale				I/O	4	down	I	
FLASH0_CLE/GPIO3_B4	AH3	gpio3b4	flash0_cle				I/O	4	down	I	
FLASH0_WRN/GPIO3_B5	AG4	gpio3b5	flash0_wrn				I/O	8	up	I	
FLASH0_CSN0/GPIO3_B6	AC5	gpio3b6	flash0_csn0				I/O	4	up	I	
FLASH0_CSN1/GPIO3_B7	AD4	gpio3b7	flash0_csn1				I/O	4	up	I	
FLASH0_CSN2/EMMC_CMD/GPIO3_C0	AC4	gpio3c0	flash0_csn2	emmc_cmd			I/O	4	up	I	
FLASH0_CSN3/EMMC_RSTNOUT/GPIO3_C1	Y7	gpio3c1	flash0_csn3	emmc_rstnout			I/O	4	up	I	
FLASH0_DQS/EMMC_CLKOUT/GPIO3_C2	AB6	gpio3c2	flash0_dqs	emmc_clkout			I/O	8	down	I	
GPIO3_C3/FLASH0_VOLTAGE_SEL	Y8	gpio3c3					I/O	4	down	I	
FLASH1_D0/HOST_D0/MAC_TXD2/SDIO1_D0/GPIO3_D0	Y4	gpio3d0	flash1_data0	host_dout0	mac_txd2	sdio1_data0	I/O	8	up	I	

Pad#	Ball#	func0	func1	func2	func3	func4	Pad type	Current	Pull	Reset State	Power Supply
FLASH1_D1/HOST_D1/MAC_TXD3/SDIO1_D1/GPIO3_D1	V6	gpio3d1	flash1_data1	host_dout1	mac_txd3	sdio1_data1	I/O	8	up	I	FLASH 1
FLASH1_D2/HOST_D2/MAC_RXD2/SDIO1_D2/GPIO3_D2	AB1	gpio3d2	flash1_data2	host_dout2	mac_rxd2	sdio1_data2	I/O	8	up	I	
FLASH1_D3/HOST_D3/MAC_RXD3/SDIO1_D3/GPIO3_D3	AC1	gpio3d3	flash1_data3	host_dout3	mac_rxd3	sdio1_data3	I/O	8	up	I	
FLASH1_D4/HOST_D4/MAC_TXD0/SDIO1_DET/GPIO3_D4	AD1	gpio3d4	flash1_data4	host_dout4	mac_txd0	sdio1_detectn	I/O	8	up	I	
FLASH1_D5/HOST_D5/MAC_TXD1/SDIO1_WRPRT/GPIO3_D5	AB2	gpio3d5	flash1_data5	host_dout5	mac_txd1	sdio1_wrprrt	I/O	8	up	I	
FLASH1_D6/HOST_D6/MAC_RXD0/SDIO1_BKPWR/GPIO3_D6	AA3	gpio3d6	flash1_data6	host_dout6	mac_rxd0	sdio1_bkpwr	I/O	8	up	I	
FLASH1_D7/HOST_D7/MAC_RXD1/SDIO1_INTN/GPIO3_D7	AA4	gpio3d7	flash1_data7	host_dout7	mac_rxd1	sdio1_intn	I/O	8	up	I	
FLASH1_RDY/HOST_CKOUTP/MAC_MDC/GPIO4_A0	AC3	gpio4a0	flash1_rdy	host_ckoutp	mac_mdc		I/O	4	up	I	
FLASH1_WP/HOST_CKOUTN/MAC_RXDV/FLASH0_CSN4/GPIO4_A1	AC2	gpio4a1	flash1_wp	host_ckoutn	mac_rxdv	flash0_csn4	I/O	4	up	I	
FLASH1_RDN/HOST_D8/MAC_RXER/FLASH0_CSN5/GPIO4_A2	AE1	gpio4a2	flash1_rdn	host_dout8	mac_rxer	flash0_csn5	I/O	4	up	I	
FLASH1_ALE/HOST_D9/MAC_CLK/FLASH0_CSN6/GPIO4_A3	AE2	gpio4a3	flash1_ale	host_dout9	mac_clk	flash0_csn6	I/O	4	up	I	
FLASH1_CLE/HOST_D10/MAC_TXEN/FLASH0_CSN7/GPIO4_A4	AD2	gpio4a4	flash1_cle	host_dout10	mac_txen	flash0_csn7	I/O	4	up	I	
FLASH1_WRN/HOST_D11/MAC_CMD/GPIO4_A5	Y5	gpio4a5	flash1_wrn	host_dout11	mac_mdio		I/O	8	up	I	
FLASH1_CSN0/HOST_D12/MAC_RXCLK/SDIO1_CMD/GPIO4_A6	AB5	gpio4a6	flash1_csn0	host_dout12	mac_rxclk	sdio1_cmd	I/O	4	up	I	
FLASH1_CSN1/HOST_D13/MAC_CRS/SDIO1_CLKOUT/GPIO4_A7	AA6	gpio4a7	flash1_csn1	host_dout13	mac_crs	sdio1_clkout	I/O	4	up	I	
FLASH1_DQS/HOST_D14/MAC_COL/FLASH1_CSN3/GPIO4_B0	AA5	gpio4b0	flash1_dqs	host_dout14	mac_col	flash1_csn3	I/O	8	up	I	
FLASH1_CSN2/HOST_D15/MAC_TXCLK/SDIO1_PWREN/GPIO4_B1	V7	gpio4b1	flash1_csn2	host_dout15	mac_txclk	sdio1_pwren	I/O	2	up	I	
UART0_RX/GPIO4_C0	AH11	gpio4c0	uart0bt_sin				I/O	2	up	I	WIFI (APIO 3)
UART0_TX/GPIO4_C1	AG10	gpio4c1	uart0bt_sout				I/O	2	down	I	
UART0_CTSN/GPIO4_C2	AB12	gpio4c2	uart0bt_ctsn				I/O	2	up	I	
UART0_RTSN/GPIO4_C3	AB11	gpio4c3	uart0bt_rtsn				I/O	2	up	I	
SDIO0_D0/GPIO4_C4	AH9	gpio4c4	sdio0_data0				I/O	4	up	I	
SDIO0_D1/GPIO4_C5	AH10	gpio4c5	sdio0_data1				I/O	4	up	I	
SDIO0_D2/GPIO4_C6	AG9	gpio4c6	sdio0_data2				I/O	4	up	I	
SDIO0_D3/GPIO4_C7	AH7	gpio4c7	sdio0_data3				I/O	4	up	I	
SDIO0_CMD/GPIO4_D0	AH8	gpio4d0	sdio0_cmd				I/O	4	up	I	
SDIO0_CLKOUT/GPIO4_D1	AG8	gpio4d1	sdio0_clkout				I/O	4	down	I	
SDIO0_DET/GPIO4_D2	AF9	gpio4d2	sdio0_detectn				I/O	2	up	I	
SDIO0_WRPRT/GPIO4_D3	AE9	gpio4d3	sdio0_wrprrt				I/O	2	down	I	
SDIO0_PWREN/GPIO4_D4	AC11	gpio4d4	sdio0_pwren				I/O	2	down	I	
SDIO0_BKPWR/GPIO4_D5	AF8	gpio4d5	sdio0_bkpwr				I/O	2	down	I	
SDIO0_INTN/GPIO4_D6	AE8	gpio4d6	sdio0_intn				I/O	2	up	I	

Pad#	Ball#	func0	func1	func2	func3	func4	Pad type	Current	Pull	Reset State	Power Supply
GPIO4_D7	AD9	gpio4d7					I/O	2	up	I	
UART1_RX/TS0_D0/GPIO5_B0	AF5	gpio5b0	uart1bb_sin	ts0_data0			I/O	2	up	I	BB (APIO 5)
UART1_TX/TS0_D1/GPIO5_B1	AA7	gpio5b1	uart1bb_sout	ts0_data1			I/O	2	down	I	
UART1_CTSN/TS0_D2/GPIO5_B2	AH4	gpio5b2	uart1bb_ctsn	ts0_data2			I/O	2	up	I	
UART1_RTSN/TS0_D3/GPIO5_B3	AD6	gpio5b3	uart1bb_rtsn	ts0_data3			I/O	2	up	I	
SPIO_CLK/TS0_D4/UART4_CTSN/GPIO5_B4	AD7	gpio5b4	spi0_clk	ts0_data4	uart4exp_ctsn		I/O	2	up	I	
SPIO_CSN0/TS0_D5/UART4_RTSN/GPIO5_B5	AC7	gpio5b5	spi0_csn0	ts0_data5	uart4exp_rtsn		I/O	2	up	I	
SPIO_TXD/TS0_D6/UART4_TX/GPIO5_B6	AE5	gpio5b6	spi0_txd	ts0_data6	uart4exp_sout		I/O	2	down	I	
SPIO_RXD/TS0_D7/UART4_RX/GPIO5_B7	AF6	gpio5b7	spi0_rxd	ts0_data7	uart4exp_sin		I/O	2	up	I	
SPIO_CSN1/TS0_SYNC/GPIO5_C0	AG5	gpio5c0	spi0_csn1	ts0_sync			I/O	2	up	I	
TS0_VALID/GPIO5_C1	AA9	gpio5c1	ts0_valid				I/O	2	down	I	
TS0_CLK/GPIO5_C2	AE6	gpio5c2	ts0_clk				I/O	2	down	I	
TS0_ERR/GPIO5_C3	AB8	gpio5c3	ts0_err				I/O	2	down	I	
I2S_SCLK/GPIO6_A0	AD11	gpio6a0	i2s_sclk				I/O	2	down	I	AUDIO (APIO 4)
I2S_LRCK_RX/GPIO6_A1	AG11	gpio6a1	i2s_lrckrx				I/O	2	down	I	
I2S_LRCK_TX/GPIO6_A2	AF11	gpio6a2	i2s_lrcktx				I/O	2	down	I	
I2S_SDI/GPIO6_A3	AE11	gpio6a3	i2s_sdi				I/O	2	down	I	
I2S_SDO0/GPIO6_A4	AG12	gpio6a4	i2s_sdo0				I/O	2	down	I	
I2S_SDO1/GPIO6_A5	AH13	gpio6a5	i2s_sdo1				I/O	2	down	I	
I2S_SDO2/GPIO6_A6	AG13	gpio6a6	i2s_sdo2				I/O	2	down	I	
I2S_SDO3/GPIO6_A7	AH12	gpio6a7	i2s_sdo3				I/O	2	down	I	
I2S_CLK/GPIO6_B0	AC12	gpio6b0	i2s_clk				I/O	4	down	I	
I2C2_SDA/GPIO6_B1	AF12	gpio6b1	i2c2audio_sda				I/O	2	up	I	
I2C2_SCL/GPIO6_B2	AD12	gpio6b2	i2c2audio_scl				I/O	2	up	I	
SPDIF_TX/GPIO6_B3	AE12	gpio6b3	spdif_tx				I/O	2	down	I	
SDMMC0_D0/JTAG_TMS/GPIO6_C0	AG7	gpio6c0	sdmmc0_data0	jtag_tms			I/O	4	up	I	SDMMC CO
SDMMC0_D1/JTAG_TRSTN/GPIO6_C1	AH6	gpio6c1	sdmmc0_data1	jtag_trstn			I/O	4	Up Down(W version)	I	
SDMMC0_D2/JTAG_TDI/GPIO6_C2	AD8	gpio6c2	sdmmc0_data2	jtag_tdi			I/O	4	up	I	
SDMMC0_D3/JTAG_TCK/GPIO6_C3	AB9	gpio6c3	sdmmc0_data3	jtag_tck			I/O	4	up	I	
SDMMC0_CLKOUT/JTAG_TDO/GPIO6_C4	AG6	gpio6c4	sdmmc0_clkout	jtag_tdo			O	4	down	O	
SDMMC0_CMD/GPIO6_C5	AC8	gpio6c5	sdmmc0_cmd				I/O	4	up	I	
SDMMC0_DECTN/GPIO6_C6	AH5	gpio6c6	sdmmc0_dectn				I/O	2	up	I	

Pad#	Ball#	func0	func1	func2	func3	func4	Pad type	Current	Pull	Reset State	Power Supply
PWM0/GPIO7_A0	H22	gpio7a0	pwm_0	vop0_pwm	vop1_pwm		I/O	2	down	I	GPIO30 (APIO1)
PWM1/GPIO7_A1	G23	gpio7a1	pwm_1				I/O	2	down	I	
GPIO7_A2	D28	gpio7a2					I/O	2	down	I	
GPIO7_A3	F25	gpio7a3					I/O	2	down	I	
GPIO7_A4	E26	gpio7a4					I/O	2	up	I	
GPIO7_A5	G24	gpio7a5					I/O	2	down	I	
GPIO7_A6	F26	gpio7a6					I/O	2	up	I	
UART3_RX/GPS_MAG/HSADC_D0_T1/GPIO7_A7	E27	gpio7a7	uart3gps_sin	gps_mag	hsadc_data0		I/O	2	up	I	
UART3_TX/GPS_SIG/HSADC_D1_T1/GPIO7_B0	J21	gpio7b0	uart3gps_sout	gps_sig	hsadc_data1		I/O	2	down	I	
UART3_CTSN/GPS_RFCLK/GPS_CLK_T1/GPIO7_B1	H23	gpio7b1	uart3gps_ctsn	gps_rfclk	gps_clk		I/O	2	up	I	
UART3_RTSN/GPIO7_B2	F27	gpio7b2	uart3gps_rtsn	usb_drvvbus0			I/O	2	up	I	
EDP_HOTPLUG/GPIO7_B3	E28	gpio7b3	usb_drvvbus1	edp_hotplug			I/O	2	down	I	
ISP_SHUTTEREN/SPI1_CLK/GPIO7_B4	J22	gpio7b4	isp_shutteren	spi1_clk			I/O	2	down	I	
ISP_FLASHTRIGOUT/SPI1_CSN0/GPIO7_B5	H24	gpio7b5	isp_flashtrigout	spi1_csn0			I/O	2	up	I	
ISP_PRELIGHTTRIG/SPI1_RXD/GPIO7_B6	F28	gpio7b6	isp_prelighttrig	spi1_rxd			I/O	2	down	I	
ISP_SHUTTERTRIG/SPI1_TXD/GPIO7_B7	G27	gpio7b7	isp_shuttertrig	spi1_txd			I/O	2	down	I	
ISP_FLASHTRIGIN/EDPHDMI_CEC_T1/GPIO7_C0	G28	gpio7c0	isp_flashtrigin	edphdmi_cecinput			I/O	2	up	I	
I2C4_SDA/GPIO7_C1	H25	gpio7c1	i2c4tp_sda				I/O	2	up	I	
I2C4_SCL/GPIO7_C2	J23	gpio7c2	i2c4tp_scl				I/O	2	up	I	
I2C5_SDA/EDPHDMI_I2C_SDA/GPIO7_C3	H26	gpio7c3	i2c5hdmi_sda	edphdmi2c_sda			I/O	2	up	I	
I2C5_SCL/EDPHDMI_I2C_SCL/GPIO7_C4	J24	gpio7c4	i2c5hdmi_scl	edphdmi2c_scl			I/O	2	up	I	
GPIO7_C5	H27	gpio7c5					I/O	2	down	I	
UART2_RX/IR_RX/PWM2/GPIO7_C6	J25	gpio7c6	uart2dbg_sin	uart2dbg_sirin	pwm_2		I/O	2	up	I	
UART2_TX/IR_TX/PWM3/EDPHDMI_CEC/GPIO7_C7	H28	gpio7c7	uart2dbg_sout	uart2dbg_sirout	pwm_3	edphdmi_cecinput	I/O	2	up	I	
PS2_CLK/GPIO8_A0	D24	gpio8a0	ps2_clk	sc_vcc18v			I/O	2	up	I	GPIO1830 (APIO2)
PS2_DATA/GPIO8_A1	C27	gpio8a1	ps2_data	sc_vcc33v			I/O	2	up	I	
GPIO8_A2/SC_DET	G21	gpio8a2	sc_detect				I/O	2	up	I	
SPI2_CSN1/SC_IO/GPIO8_A3	B28	gpio8a3	spi2_csn1	sc_io			I/O	2	up	I	
I2C1_SDA/SC_RST/GPIO8_A4	A28	gpio8a4	i2c1sensor_sda	sc_rst			I/O	2	up	I	
I2C1_SCL/SC_CLK/GPIO8_A5	E25	gpio8a5	i2c1sensor_scl	sc_clk			I/O	2	up	I	
SPI2_CLK/SC_IO_T1/GPIO8_A6	D26	gpio8a6	spi2_clk	sc_io			I/O	2	down	I	
SPI2_CSN0/SC_DET_T1/GPIO8_A7	D27	gpio8a7	spi2_csn0	sc_detect			I/O	2	up	I	

Pad#	Ball#	func0	func1	func2	func3	func4	Pad type	Current	Pull	Reset State	Power Supply
SPI2_RXD/SC_RST_T1/GPIO8_B0	F24	gpio8b0	spi2_rxd	sc_rst			I/O	2	down	I	
SPI2_TXD/SC_CLK_T1/GPIO8_B1	C28	gpio8b1	spi2_txd	sc_clk			I/O	2	down	I	
BSJTAGTMS	G20	bsjtagtms					I	2	up	I	
BSJTAGRSTN	E22	bsjtagtrstn					I	2	up	I	
BSJTAGTDI	F21	bsjtagtdi					I	2	up	I	
BSJTAGTCK	E23	bsjtagtck					I	2	up	I	
BSJTAGTDO	F22	bsjtagtdo					O	2	N/A	O	
LVDS_DATAP0	T27	lvds_padp0	lcdc0_data0	trace_data0			A			NA	LVDS
LVDS_DATAN0	T28	lvds_padn0	lcdc0_data1	trace_data1			A			NA	
LVDS_DATAP1	U27	lvds_padp1	lcdc0_data2	trace_data2			A			NA	
LVDS_DATAN1	U28	lvds_padn1	lcdc0_data3	trace_data3			A			NA	
LVDS_DATAP2	W27	lvds_padp2	lcdc0_data4	trace_data4			A			NA	
LVDS_DATAN2	W28	lvds_padn2	lcdc0_data5	trace_data5			A			NA	
LVDS_DATAP3	Y27	lvds_padp3	lcdc0_data6	trace_data6			A			NA	
LVDS_DATAN3	Y28	lvds_padn3	lcdc0_data7	trace_data7			A			NA	
LVDS_DATAP4	AA27	lvds_padp4	lcdc0_data8	trace_data8			A			NA	
LVDS_DATAN4	AA28	lvds_padn4	lcdc0_data9	trace_data9			A			NA	
LVDS_CLKP0	V27	lvds_clkp0	lcdc0_data10	trace_data10			A			NA	
LVDS_CLKN0	V28	lvds_clkn0	lcdc0_data11	trace_data11			A			NA	
LVDS_DATAP5	U25	lvds_padp5	lcdc0_data12	trace_data12			A			NA	
LVDS_DATAN5	U26	lvds_padn5	lcdc0_data13	trace_data13			A			NA	
LVDS_DATAP6	V25	lvds_padp6	lcdc0_data14	trace_data14			A			NA	
LVDS_DATAN6	V26	lvds_padn6	lcdc0_data15	trace_data15			A			NA	
LVDS_DATAP7	AA25	lvds_padp7	lcdc0_data16	trace_clk			A			NA	
LVDS_DATAN7	AA26	lvds_padn7	lcdc0_data17	trace_ctl			A			NA	
LVDS_DATAP8	AB27	lvds_padp8	lcdc0_data18				A			NA	
LVDS_DATAN8	AB28	lvds_padn8	lcdc0_data19				A			NA	
LVDS_DATAP9	AC25	lvds_padp9	lcdc0_data20				A			NA	
LVDS_DATAN9	AC26	lvds_padn9	lcdc0_data21				A			NA	
LVDS_CLKP1	Y25	lvds_clkp1	lcdc0_data22				A			NA	
LVDS_CLKN1	Y26	lvds_clkn1	lcdc0_data23				A			NA	
ADC_IN2	P23	saradc_ain2					A			NA	SARADC
ADC_IN1	P21	saradc_ain1					A			NA	
ADC_IN0	P24	saradc_ain0					A			NA	
MIPI_TXRX_D0N	AF20	mip_itxrx_d0n					A			NA	MIPI

Pad#	Ball#	func0	func1	func2	func3	func4	Pad type	Current	Pull	Reset State	Power Supply
MIPI_TXRX_D0P	AE20	mip_itrx_d0p					A			NA	
MIPI_TXRX_D1P	AE21	mip_itrx_d1p					A			NA	
MIPI_TXRX_D1N	AF21	mip_itrx_d1n					A			NA	
MIPI_TXRX_CLKN	AF23	mip_itrx_clkn					A			NA	
MIPI_TXRX_CLKP	AE23	mip_itrx_clkp					A			NA	
MIPI_TXRX_D2N	AF24	mip_itrx_d2n					A			NA	
MIPI_TXRX_D2P	AE24	mip_itrx_d2p					A			NA	
MIPI_TXRX_D3N	AD25	mip_itrx_d3n					A			NA	
MIPI_TXRX_D3P	AF25	mip_itrx_d3p					A			NA	
MIPI_TXRX_REXT	AD22	mip_itrx_rext					A			NA	
MIPI_TX_REXT	AE26	mipi_tx_rext					A			NA	
MIPI_TX_D3P	AC27	mipi_tx_d3p					A			NA	
MIPI_TX_D3N	AC28	mipi_tx_d3n					A			NA	
MIPI_TX_D2N	AD28	mipi_tx_d2n					A			NA	
MIPI_TX_D2P	AD27	mipi_tx_d2p					A			NA	
MIPI_TX_CLKP	AE27	mipi_tx_clkp					A			NA	
MIPI_TX_CLKN	AE28	mipi_tx_clkn					A			NA	
MIPI_TX_D1P	AF27	mipi_tx_d1p					A			NA	
MIPI_TX_D1N	AF28	mipi_tx_d1n					A			NA	
MIPI_TX_D0N	AG28	mipi_tx_d0n					A			NA	
MIPI_TX_D0P	AG27	mipi_tx_d0p					A			NA	
MIPI_RX_REXT	AD21	mipi_rx_rext					A			NA	
MIPI_RX_D3N	AH27	mipi_rx_d3n					A			NA	
MIPI_RX_D3P	AH28	mipi_rx_d3p					A			NA	
MIPI_RX_D2N	AH26	mipi_rx_d2n					A			NA	
MIPI_RX_D2P	AG26	mipi_rx_d2p					A			NA	
MIPI_RX_CLKP	AG25	mipi_rx_clkp					A			NA	
MIPI_RX_CLKN	AH25	mipi_rx_clkn					A			NA	
MIPI_RX_D1P	AG24	mipi_rx_d1p					A			NA	
MIPI_RX_D1N	AH24	mipi_rx_d1n					A			NA	
MIPI_RX_D0P	AG23	mipi_rx_d0p					A			NA	
MIPI_RX_D0N	AH23	mipi_rx_d0n					A			NA	
HDMI_TX2P	AG22	hdmi_tx2p					A			NA	HDMI

Pad#	Ball#	func0	func1	func2	func3	func4	Pad type	Current	Pull	Reset State	Power Supply
HDMI_TX2N	AH22	hdmi_tx2n					A			NA	
HDMI_TX1P	AG21	hdmi_tx1p					A			NA	
HDMI_TX1N	AH21	hdmi_tx1n					A			NA	
HDMI_TX0P	AG20	hdmi_tx0p					A			NA	
HDMI_TX0N	AH20	hdmi_tx0n					A			NA	
HDMI_TCN	AH19	hdmi_tcn					A			NA	
HDMI_TCP	AG19	hdmi_tcp					A			NA	
HDMI_REXT	AB17	hdmi_rext					A			NA	
HDMI_HPD	AB18	hdmi_hpd					A			NA	
EDP_TP_OUT	AA12	edp_tp_out					A			NA	
EDP_REXT	AC18	edp_rext					A			NA	eDP
EDP_CLK24M_IN	AC17	edp_clk24m_in					A			NA	
EDP_AUXN	AH18	edp_auxn					A			NA	
EDP_AUXP	AG18	edp_auxp					A			NA	
EDP_TX3P	AG17	edp_tx3p					A			NA	
EDP_TX3N	AH17	edp_tx3n					A			NA	
EDP_TX2N	AH16	edp_tx2n					A			NA	
EDP_TX2P	AG16	edp_tx2p					A			NA	
EDP_TX1N	AH15	edp_tx1n					A			NA	
EDP_TX1P	AG15	edp_tx1p					A			NA	
EDP_TX0P	AG14	edp_tx0p					A			NA	
EDP_TX0N	AH14	edp_tx0n					A			NA	
DDR1_DQ7	Y3	ddr1_dq7					A			NA	DDR1
DDR1_DQ6	V5	ddr1_dq6					A			NA	
DDR1_DQ5	Y2	ddr1_dq5					A			NA	
DDR1_DQS0	AA2	ddr1_dqs0					A			NA	
DDR1_DQS0N	AA1	ddr1_dqsn0					A			NA	
DDR1_DQ4	W1	ddr1_dq4					A			NA	
DDR1_DQ3	U6	ddr1_dq3					A			NA	
DDR1_DQ2	Y1	ddr1_dq2					A			NA	
DDR1_DQ1	V3	ddr1_dq1					A			NA	
DDR1_DQ0	W2	ddr1_dq0					A			NA	
DDR1_DM0	U5	ddr1_dm0					A			NA	
DDR1_VREF	M8	ddr1_vref0					P			NA	
DDR1_DQ23	V2	ddr1_dq23					A			NA	

Pad#	Ball#	func0	func1	func2	func3	func4	Pad type	Current	Pull	Reset State	Power Supply
DDR1_DQ22	U3	ddr1_dq22					A			NA	
DDR1_DQ21	V1	ddr1_dq21					A			NA	
DDR1_DQ20	U4	ddr1_dq20					A			NA	
DDR1_DQS2	U2	ddr1_dqs2					A			NA	
DDR1_DQS2N	U1	ddr1_dqn2					A			NA	
DDR1_DQ19	R5	ddr1_dq19					A			NA	
DDR1_DQ18	T1	ddr1_dq18					A			NA	
DDR1_DQ17	R6	ddr1_dq17					A			NA	
DDR1_DQ16	T2	ddr1_dq16					A			NA	
DDR1_DM2	R3	ddr1_dm2					A			NA	
DDR1_PZQ	U7	ddr1_pzq					A			NA	
DDR1_ATO	M7	ddr1_ato					A			NA	
DDR1_DTO1	R8	ddr1_dto1					A			NA	
DDR1_DTO0	U8	ddr1_dto0					A			NA	
DDR1_ODT1	R2	ddr1_odt1					A			NA	
DDR1_ODT0	P5	ddr1_odt0					A			NA	
DDR1_A15	R1	ddr1_a15					A			NA	
DDR1_VREF	M8	ddr1_vref1					P			NA	
DDR1_A14	P2	ddr1_a14					A			NA	
DDR1_A13	P3	ddr1_a13					A			NA	
DDR1_A12	P6	ddr1_a12					A			NA	
DDR1_A11	P4	ddr1_a11					A			NA	
DDR1_A10	N2	ddr1_a10					A			NA	
DDR1_A9	P1	ddr1_a9					A			NA	
DDR1_A8	N1	ddr1_a8					A			NA	
DDR1_A7	M3	ddr1_a7					A			NA	
DDR1_A6	M1	ddr1_a6					A			NA	
DDR1_A5	M2	ddr1_a5					A			NA	
DDR1_CK	L2	ddr1_ck					A			NA	
DDR1_CKN	L1	ddr1_ckn					A			NA	
DDR1_A4	M6	ddr1_a4					A			NA	
DDR1_A3	M5	ddr1_a3					A			NA	
DDR1_A2	K1	ddr1_a2					A			NA	
DDR1_A1	K2	ddr1_a1					A			NA	
DDR1_A0	L3	ddr1_a0					A			NA	

Pad#	Ball#	func0	func1	func2	func3	func4	Pad type	Current	Pull	Reset State	Power Supply
DDR1_BA2	L5	ddr1_ba2					A			NA	
DDR1_BA1	J1	ddr1_ba1					A			NA	
DDR1_BA0	L4	ddr1_ba0					A			NA	
DDR1_RASN	L6	ddr1_rasn					A			NA	
DDR1_CASN	H1	ddr1_casn					A			NA	
DDR1_WEN	J2	ddr1_wen					A			NA	
DDR1_CS1N	J3	ddr1_csn1					A			NA	
DDR1_CS0N	H2	ddr1_csn0					A			NA	
DDR1_CKE1	H3	ddr1_cke1					A			NA	
DDR1_CKE0	F1	ddr1_cke0					A			NA	
DDR1_RESET	F2	ddr1_reset					A			NA	
DDR1_VREFAO	L8	ddr1_vref2					P			NA	
DDR1_RETLE	H7	ddr1_retie					A			NA	
DDR1_DQ15	J6	ddr1_dq15					A			NA	
DDR1_DQ14	J5	ddr1_dq14					A			NA	
DDR1_DQ13	H4	ddr1_dq13					A			NA	
DDR1_DQ12	H5	ddr1_dq12					A			NA	
DDR1_DQS1	G2	ddr1_dqs1					A			NA	
DDR1_DQS1N	G1	ddr1_dqs1n					A			NA	
DDR1_DQ11	F3	ddr1_dq11					A			NA	
DDR1_DQ10	C1	ddr1_dq10					A			NA	
DDR1_DQ9	E1	ddr1_dq9					A			NA	
DDR1_DQ8	E2	ddr1_dq8					A			NA	
DDR1_DM1	G5	ddr1_dm1					A			NA	
DDR1_VREF	M8	ddr1_vref3					P			NA	
DDR1_DQ31	H6	ddr1_dq31					A			NA	
DDR1_DQ30	C2	ddr1_dq30					A			NA	
DDR1_DQ29	F5	ddr1_dq29					A			NA	
DDR1_DQ28	E3	ddr1_dq28					A			NA	
DDR1_DQS3	D2	ddr1_dqs3					A			NA	
DDR1_DQS3N	D1	ddr1_dqs3n					A			NA	
DDR1_DQ27	G6	ddr1_dq27					A			NA	
DDR1_DQ26	E4	ddr1_dq26					A			NA	
DDR1_DQ25	B2	ddr1_dq25					A			NA	
DDR1_DQ24	B1	ddr1_dq24					A			NA	

Pad#	Ball#	func0	func1	func2	func3	func4	Pad type	Current	Pull	Reset State	Power Supply
DDR1_DM3	D3	ddr1_dm3					A			NA	DDR0
DDR0_DM3	B3	ddr0_dm3					A			NA	
DDR0_DQ24	A2	ddr0_dq24					A			NA	
DDR0_DQ25	A1	ddr0_dq25					A			NA	
DDR0_DQ26	D5	ddr0_dq26					A			NA	
DDR0_DQ27	E6	ddr0_dq27					A			NA	
DDR0_DQS3N	A4	ddr0_dqsn3					A			NA	
DDR0_DQS3	B4	ddr0_dqs3					A			NA	
DDR0_DQ28	C5	ddr0_dq28					A			NA	
DDR0_DQ29	F7	ddr0_dq29					A			NA	
DDR0_DQ30	C4	ddr0_dq30					A			NA	
DDR0_DQ31	E7	ddr0_dq31					A			NA	
DDR0_VREF	H12	ddr0_vref3					P			NA	
DDR0_DM1	F9	ddr0_dm1					A			NA	
DDR0_DQ8	B5	ddr0_dq8					A			NA	
DDR0_DQ9	A5	ddr0_dq9					A			NA	
DDR0_DQ10	A3	ddr0_dq10					A			NA	
DDR0_DQ11	C6	ddr0_dq11					A			NA	
DDR0_DQS1N	A7	ddr0_dqsn1					A			NA	
DDR0_DQS1	B7	ddr0_dqs1					A			NA	
DDR0_DQ12	E8	ddr0_dq12					A			NA	
DDR0_DQ13	A6	ddr0_dq13					A			NA	
DDR0_DQ14	B6	ddr0_dq14					A			NA	
DDR0_DQ15	F8	ddr0_dq15					A			NA	
DDR0_RETLE	G8	ddr0_retle					A			NA	
DDR0_VREFA0	H11	ddr0_verf2					P			NA	
DDR0_RESET	E9	ddr0_reset					A			NA	
DDR0_CKE0	C9	ddr0_cke0					A			NA	
DDR0_CKE1	C8	ddr0_cke1					A			NA	
DDR0_CS0N	B8	ddr0_csn0					A			NA	
DDR0_CS1N	F11	ddr0_csn1					A			NA	
DDR0_WEN	B9	ddr0_wen					A			NA	
DDR0_CASN	A8	ddr0_casn					A			NA	
DDR0_RASN	D11	ddr0_rasn					A			NA	
DDR0_BA0	D8	ddr0_ba0					A			NA	

Pad#	Ball#	func0	func1	func2	func3	func4	Pad type	Current	Pull	Reset State	Power Supply
DDR0_BA1	A9	ddr0_ba1					A			NA	
DDR0_BA2	E11	ddr0_ba2					A			NA	
DDR0_A0	B10	ddr0_a0					A			NA	
DDR0_A1	C11	ddr0_a1					A			NA	
DDR0_A2	A10	ddr0_a2					A			NA	
DDR0_A3	E12	ddr0_a3					A			NA	
DDR0_A4	F12	ddr0_a4					A			NA	
DDR0_CKN	A11	ddr0_ckn					A			NA	
DDR0_CK	B11	ddr0_ck					A			NA	
DDR0_A5	B12	ddr0_a5					A			NA	
DDR0_A6	C12	ddr0_a6					A			NA	
DDR0_A7	A12	ddr0_a7					A			NA	
DDR0_A8	B13	ddr0_a8					A			NA	
DDR0_A9	A14	ddr0_a9					A			NA	
DDR0_A10	A13	ddr0_a10					A			NA	
DDR0_A11	D14	ddr0_a11					A			NA	
DDR0_A12	F14	ddr0_a12					A			NA	
DDR0_A13	C14	ddr0_a13					A			NA	
DDR0_A14	B14	ddr0_a14					A			NA	
DDR0_VREF	H12	ddr0_vref1					P			NA	
DDR0_A15	C15	ddr0_a15					A			NA	
DDR0_ODT0	E14	ddr0_odt0					A			NA	
DDR0_ODT1	E15	ddr0_odt1					A			NA	
DDR0_DTO0	H17	ddr0_dto0					A			NA	
DDR0_DTO1	H15	ddr0_dto1					A			NA	
DDR0_ATO	G12	ddr0_ato					A			NA	
DDR0_PZQ	G17	ddr0_pzq					A			NA	
DDR0_DM2	A15	ddr0_dm2					A			NA	
DDR0_DQ16	B15	ddr0_dq16					A			NA	
DDR0_DQ17	A16	ddr0_dq17					A			NA	
DDR0_DQ18	F15	ddr0_dq18					A			NA	
DDR0_DQ19	B16	ddr0_dq19					A			NA	
DDR0_DQS2N	A17	ddr0_dqsn2					A			NA	
DDR0_DQS2	B17	ddr0_dqs2					A			NA	
DDR0_DQ20	D17	ddr0_dq20					A			NA	

Pad#	Ball#	func0	func1	func2	func3	func4	Pad type	Current	Pull	Reset State	Power Supply
DDR0_DQ21	B18	ddr0_dq21					A			NA	
DDR0_DQ22	C17	ddr0_dq22					A			NA	
DDR0_DQ23	A18	ddr0_dq23					A			NA	
DDR0_VREF	H12	ddr0_vref0					P			NA	
DDR0_DM0	E17	ddr0_dm0					A			NA	
DDR0_DQ0	B19	ddr0_dq0					A			NA	
DDR0_DQ1	C18	ddr0_dq1					A			NA	
DDR0_DQ2	F17	ddr0_dq2					A			NA	
DDR0_DQ3	F18	ddr0_dq3					A			NA	
DDR0_DQ4	A19	ddr0_dq4					A			NA	
DDR0_DQS0N	B20	ddr0_dqs0					A			NA	
DDR0_DQS0	A20	ddr0_dqs0					A			NA	
DDR0_DQ5	E18	ddr0_dq5					A			NA	
DDR0_DQ6	C20	ddr0_dq6					A			NA	
DDR0_DQ7	D20	ddr0_dq7					A			NA	
USBHOST2_DP	B22	usbhost1_dp					A			NA	USBH OST1
USBHOST2_DM	A22	usbhost1_dm					A			NA	
USBHOST2_TXRTUNE	C21	usbhost1_txrtune					A			NA	
USBHOST1_DP	B23	usbhost1_dp					A			NA	USBH OST0
USBHOST1_DM	A23	usbhost1_dm					A			NA	
USBHOST1_TXRTUNE	C23	usbhost1_txrtune					A			NA	
USBOTG_ID	C25	usbotg_id					A			NA	USBOT G
USBOTG_VBUS	D23	usbotg_vbus					A			NA	
USBOTG_DP	B26	usbotg_dp					A			NA	
USBOTG_DM	A26	usbotg_dm					A			NA	
USBOTG_TXRTUNE	D21	usbotg_txrtune					A			NA	
USIC_STROBE	B27	usic_strobe					A			NA	USIC
USIC_DATA	A27	usic_data					A			NA	

Notes :

①: Pad types : I = input , O = output , I/O = input/output (bidirectional) ,
 AP = Analog Power , AG = Analog Ground
 DP = Digital Power , DG = Digital Ground
 A = Analog

②: Output Drive strength is configurable, it's the suggested value in this table. Unit is mA , only Digital IO have drive value

③:Reset state: I = input without any pull resistor O = output

④:It is die location. For examples, "Left side" means that all the related IOs are always in left side of die

⑤:Power supply means that all the related IOs are in this IO power domain. If multiple powers are included, they are connected together in one IO power ring

⑥:The pull up/pull down is configurable.

Rockchip Confidential

2.8 IO pin name descriptions

This sub-chapter will focus on the detailed function description of every pins based on different interface.

Table 2-3 RK3288 IO function description list

Interface	Pin Name	Direction	Description
Misc	XIN24M	I	Clock input of 24MHz crystal
	XOUT24M	O	Clock output of 24MHz crystal
	CLK32K	I	Clock input of 32.768KHz
	NPOR	I	Chip hardware reset
	SECURITYSEL	I	Security solution selection
	clk_27m	I	External 27MHz clock input
	global_pwroff	O	Request signal to external PMIC for power down CPU subsystem with qual-core Cortex-A17 or power down SoC Core logic w/o Cortex-A17 subsystem and PMU logic
	ddrio_pwroff	O	Request signal to external PMIC for power down DDR IO
	ddrio0_reten	O	DDR0 IO retention control
	ddrio1_reten	O	DDR1 IO retention control
	tsadc_int	O	TSADC trigger to shut down chip

Interface	Pin Name	Direction	Description
	jtag_trstn	I	JTAG interface reset input
	jtag_tck	I	JTAG interface clock input/SWD interface clock input
	jtag_tdi	I	JTAG interface TDI input
	jtag_tms	I/O	JTAG interface TMS input/SWD interface data out
	jtag_tdo	O	JTAG interface TDO output

Interface	Pin Name	Direction	Description
ETM Trace	trace_clk	O	Cortex-A17 ETM trace port clk
	trace_ctl	O	Cortex-A17 ETM trace port control
	trace_data <i>(i=0~15)</i>	O	Cortex-A17 ETM trace port data

Interface	Pin Name	Direction	Description
SD/MMC Host Controller	sdmmc0_clkout	O	sdmmc card clock.
	sdmmc0_cmd	I/O	sdmmc card command output and reponse input.
	sdmmc0_data <i>(i=0~3)</i>	I/O	sdmmc card data input and output.
	sdmmc0_detect_n	I	sdmmc card detect signal, a 0 represents presence of card.

Interface	Pin Name	Direction	Description
SDIO Host Controller	sdiox_clkout(<i>x=0,1</i>)	O	sdio card clock.
	sdiox_cmd(<i>x=0,1</i>)	I/O	sdio card command output and reponse input.

Interface	Pin Name	Direction	Description
(2 channel)	sdiox_data <i>i</i> (<i>i</i> =0~3) (<i>x</i> =0,1)	I/O	sdio card data input and output.
	sdiox_detectn(<i>x</i> =0,1)	I	sdio card detect signal, a 0 represents presence of card.
	sdiox_wrprt(<i>x</i> =0,1)	I	sdio card write protect signal, a 1 represents write is protected.
	sdiox_pwren(<i>x</i> =0,1)	O	sdio card power-enable control signal
	sdiox_intn(<i>x</i> =0,1)	O	sdio card interrupt indication
	sdiox_bkpwr(<i>x</i> =0,1)	O	the back-end power supply for embedded device

Interface	Pin Name	Direction	Description
eMMC Interface	emmc_clkout	O	emmc card clock.
	emmc_cmd	I/O	emmc card command output and reponse input.
	emmc_data <i>i</i> (<i>i</i> =0~7)	I/O	emmc card data input and output.
	emmc_pwren	O	emmc card power-enable control signal
	emmc_rstnout	O	emmc card reset signal

Interface	Pin Name	Direction	Description
DMC (2 channel)	DDR <i>x</i> _CK(<i>x</i> =0,1)	O	Active-high clock signal to the memory device.
	DDR <i>x</i> _CK_N(<i>x</i> =0,1)	O	Active-low clock signal to the memory device.
	DDR <i>x</i> _CKE <i>i</i> (<i>i</i> =0,1) (<i>x</i> =0,1)	O	Active-high clock enable signal to the memory device for two chip select.
	DDR <i>x</i> _CSN <i>i</i> (<i>i</i> =0,1) (<i>x</i> =0,1)	O	Active-low chip select signal to the memory device. AThere are two chip select.
	DDR <i>x</i> _RASN(<i>x</i> =0,1)	O	Active-low row address strobe to the memory device.
	DDR <i>x</i> _CASN(<i>x</i> =0,1)	O	Active-low column address strobe to the memory device.
	DDR <i>x</i> _WEN(<i>x</i> =0,1)	O	Active-low write enable strobe to the memory device.
	DDR <i>x</i> _BA[2:0] (<i>x</i> =0,1)	O	Bank address signal to the memory device.
	DDR <i>x</i> _ADDR[15:0] (<i>x</i> =0,1)	O	Address signal to the memory device.
	DDR <i>x</i> _DQ[31:0] (<i>x</i> =0,1)	I/O	Bidirectional data line to the memory device.
	DDR <i>x</i> _DQS[3:0] (<i>x</i> =0,1)	I/O	Active-high bidirectional data strobes to the memory device.
	DDR <i>x</i> _DQS_B[3:0] (<i>x</i> =0,1)	I/O	Active-low bidirectional data strobes to the memory device.
	DDR <i>x</i> _DM[3:0] (<i>x</i> =0,1)	O	Active-low data mask signal to the memory device.
	DDR <i>x</i> _ODT <i>i</i> (<i>i</i> =0,1) (<i>x</i> =0,1)	O	On-Die Termination output signal for two chip select.
	DDR <i>x</i> _RETEN(<i>x</i> =0,1)	I	Active-low retention latch enable input
	DDR <i>x</i> _RESET(<i>x</i> =0,1)	O	DDR3 reset signal to the memory device
	DDR <i>x</i> _VREF <i>i</i> (<i>i</i> =0,1,2,3) (<i>x</i> =0,1)	I/O	Reference Voltage input for three regions of DDR IO
	DDR <i>x</i> _PZQ(<i>x</i> =0,1)	I/O	ZQ calibration pad which connects 240ohm±1% resistor

Interface	Pin Name	Direction	Description
NandC (2 channel)	flashx_wp(<i>x</i> =0,1)	O	Flash write-protected signal
	flashx_ale(<i>x</i> =0,1)	O	Flash address latch enable signal

Interface	Pin Name	Direction	Description
	flashx_cle(x=0,1)	O	Flash command latch enable signal
	flashx_wrn(x=0,1)	O	Flash write enable and clock signal
	flashx_rdn(x=0,1)	O	Flash read enable and write/read signal
	flashx_datai(i=0~7) (x=0,1)	I/O	Flash data inputs/outputs signal
	flashx_dqs(x=0,1)	I/O	Flash data strobe signal
	flashx_rdy(x=0,1)	I	Flash ready/busy signal
	flashx_csni(i=0~7) (x=0,1)	O	Flash chip enable signal for chip i, i=0~7

Interface	Pin Name	Direction	Description
HSADC Interface	hsadc_clkout	I/O	hsadc input /output clock
	hsadc_datai (i=0~9)	I	hsadc(i=0~9)/tsi(i=0~7)/gps data(i=0,1)
	hsadc_sync	I	ts synchronizer signal
	hsadc_valid	I	ts valid signal
	hsadc_fail	I	ts fail signal
	gps_clk	I	hsadc/tsi/gps reference clock

Interface	Pin Name	Direction	Description
TSP Interface	ts0_clk	I/O	TSI reference clock
	ts0_datai (i=0~7)	I	TSI data(i=0~7)
	ts0_sync	I	TSI synchronizer signal
	ts0_valid	I	TSI valid signal
	ts0_err	I	TSI fail signal

Interface	Pin Name	Direction	Description
I2S/PCM Controller	i2s_clk	O	I2S/PCM1 clock source
	i2s_sclk	I/O	I2S/PCM1 serial clock
	i2s_lrckrx	I/O	I2S/PCM1 left & right channel signal for receiving serial data, synchronous left & right channel in I2S mode and the beginning of a group of left & right channels in PCM mode
	i2s_sdi	I	I2S/PCM1 serial data input
	i2s_sdoi (i=0~9)	O	I2S/PCM1 serial data output
	i2s_lrcktx	I/O	I2S/PCM1 left & right channel signal for transmitting serial data, synchronous left & right channel in I2S mode and the beginning of a group of left & right channels in PCM mode

Interface	Pin Name	Direction	Description
SPDIF transmitter	spdif_tx	O	spdif biphas data output

Interface	Pin Name	Direction	Description
SPI Controller	spix_clk(x=0,2)	I/O	spi serial clock
	spix_csny (x=0,2)(y=0,1)	I/O	spi chip select signal, low active
	spix_txd(x=0,2)	O	spi serial data output

Interface	Pin Name	Direction	Description
	spix_rxd(x=0,2)	I	spi serial data input

Interface	Pin Name	Direction	Description
LCD	lcdc0_dclk	O	LCDC RGB interface display clock out, MCU i80 interface RS signal
	lcdc0_vsync	O	LCDC RGB interface vertical sync pulse, MCU i80 interface CSN signal
	lcdc0_hsync	O	LCDC RGB interface horizontal sync pulse, MCU i80 interface WEN signal
	lcdc0_den	O	LCDC RGB interface data enable, MCU i80 interface REN signal
	lcdc0_data <i>i</i> (<i>i</i> =0~23)	O	LCDC data output/input
	vop0_pwm	O	VOP_BIG CABAC PWM control signal
	vop1_pwm	O	VOP_LIT CABAC PWM control signal

Interface	Pin Name	Direction	Description
Camera IF	cif_clk	I	Camera0 interface input pixel clock
	cif_clkout	O	Camera0 interface output work clock
	cif_vsync	I	Camera0 interface vertical sync signal
	cif_href	I	Camera0 interface horizontal sync signal
	cif_data <i>i</i> (<i>i</i> =0~11)	I	Camera0 interface input pixel data

Interface	Pin Name	Direction	Description
PWM	pwm3	I/O	Pulse Width Modulation output
	pwm2	I/O	Pulse Width Modulation output
	pwm1	I/O	Pulse Width Modulation output
	pwm0	I/O	Pulse Width Modulation output

Interface	Pin Name	Direction	Description
GPS	gps_rfclk	I	GPS reference clock
	gps_sig	I	GPS SIG input
	gps_mag	I	GPS MAG input

Interface	Pin Name	Direction	Description
PS2	ps2_clk	I/O	P2S clock signal
	ps2_data	I/O	P2S data signal

Interface	Pin Name	Direction	Description
I2C	i2c0pmu_sda	I/O	I2C_PMU data
	i2c0pmu_scl	I/O	I2C_PMU clock
	i2c1sensor_sda	I/O	I2C1_SENSOR data
	i2c1sensor_scl	I/O	I2C1_SENSOR clock
	i2c2audio_sda	I/O	I2C2_AUDIO data
	i2c2audio_scl	I/O	I2C2_AUDIO clock
	i2c3cam_sda	I/O	I2C3_CAM data
	i2c3cam_scl	I/O	I2C3_CAM clock
	i2c4tp_sda	I/O	I2C4_TP data

Interface	Pin Name	Direction	Description
	i2c4tp_scl	I/O	I2C4_TP clock
	i2c4hdmi_sda	I/O	I2C5_HDMI data
	i2c4hdmi_scl	I/O	I2C5_HDMI clock

Interface	Pin Name	Direction	Description
UART	uart0bt_sin	I	UART_BT searial data input
	uart0bt_sout	O	UART_BT searial data output
	uart0bt_ctsn	I	UART_BT clear to send
	uart0bt_rtsn	O	UART_BT request to send
	uart1bb_sin	I	UART_BB searial data input
	uart1bb_sout	O	UART_BB searial data output
	uart1bb_ctsn	O	UART_BB clear to send
	uart1bb_rtsn	I	UART_BB request to send
	uart2dbg_sin	I	UART_DBG searial data input
	uart2dbg_sout	O	UART_DBG searial data output
	uart3gps_sin	I	UART_GPS searial data input
	uart3gps_sout	O	UART_GPS searial data output
	uart3gps_ctsn	I	UART_GPS clear to send
	uart3gps_rtsn	O	UART_GPS request to send
	uart4exp_sin	I	UART_EXP searial data input
	uart4exp_sout	O	UART_EXP searial data output
	uart4exp_ctsn	I	UART_EXP clear to send
	uart4exp_rtsn	O	UART_EXP request to send

Interface	Pin Name	Direction	Description
GMAC	mac_clk	I/O	RMII REC_CLK output or GMAC external clock input
	mac_txclk	O	RGMII TX clock output
	mac_rxclk	I	RGMII RX clock input
	mac_mdc	O	GMAC management interface clock
	mac_mdio	I/O	GMAC management interface data
	mac_txd(i=0~3)	O	GMAC TX data
	max_rxd(i=0~3)	I	GMAC RX data
	mac_txen	O	GMAC TX data enable
	mac_rxdv	I	GMAC RX data valid signal
	mac_rxer	I	GMAC RX error signal
	mac_col	I	PHY Collision signal
	mac_crs	I	PHY CRS signal

Interface	Pin Name	Direction	Description
HOST interface	host_dini(i=0~7)	I/O	Host data(8bit for input or output)
	host_dout(i=0~15)	I/O	Host data(16bit for input or output)
	host_ckinp	I/O	Host differential clock p pin(for input or output)
	host_ckinn	I/O	Host differential clock n pin(for input or output)
	host_ckoutp	I/O	Host differential clock p pin(for input or output)
	host_ckoutn	I/O	Host differential clock n pin(for input or output)

Interface	Pin Name	Direction	Description
	host_wkack	I	Host interface wakeup acknowledge
	host_wkreq	O	Host interface wakeup request

Interface	Pin Name	Direction	Description
USB OTG 2.0	OTG_DM	N/A	USB OTG 2.0 Data signal DM
	OTG_RKELVIN	N/A	USB OTG 2.0 Transmitter Kelvin Connection to Resistor Tune Pin
	OTG_DP	N/A	USB OTG 2.0 Data signal DP
	OTG_VBUS	N/A	USB OTG 2.0 5-V power supply pin
	usb_drvvbus	O	USB OTG 2.0 drive VBUS

Interface	Pin Name	Direction	Description
USB Host 2.0 (2 channel)	HOSTx_DM(x=0,1)	N/A	USB HOST 2.0 Data signal DM
	HOSTx_RBIAS(x=0,1)	N/A	135 Ω Reference external resistance
	HOSTx_DP(x=0,1)	N/A	USB HOST 2.0 Data signal DP
	HOSTx_VBUS(x=0,1)	N/A	USB HOST 2.0 5-V power supply pin

Interface	Pin Name	Direction	Description
USIC	USIC_DATA	N/A	USIC DATA signal
	USIC_STROBE	N/A	USIC STROBE signal

Interface	Pin Name	Direction	Description
SAR-ADC	SARADC_AIN[i] (i=0~2)	N/A	SAR-ADC input signal for 3 channel

Interface	Pin Name	Direction	Description
eFuse	EFUSE_VDDQ	N/A	eFuse program and sense power

Interface	Pin Name	Direction	Description
SIM Card	sc_clk	O	Smart card clock output
	sc_rst	O	Smart card reset output
	sc_io	I/O	Smart card data
	sc_detect	O	Smart card detect input
	sc_vcc18v	O	Smart card 1.8V voltage select
	sv_vcc33v	O	Smart card 3.3V voltage select

Interface	Pin Name	Direction	Description
ISP	isp_shutteren	O	Hold signal for shutter open
	isp_flashtrigout	O	Hold signal for flash light
	isp_prelighttrig	O	Hold signal for prelight
	isp_shuttertrig	I	External shutter trigger pulse
	isp_flashtrigin	I	External flash trigger pulse

Interface	Pin Name	Direction	Description
LVDS	LVDS_PADPi(i=0~9)	I/O	LVDS/TTL data lane serial pin
	LVDS_PADNi(i=0~9)	I/O	LVDS/TTL data lane serial pin
	LVDS_CLKPi(i=0~1)	I/O	LVDS clock lane/TTL data lane serial pin
	LVDS_CLKNi(i=0~1)	I/O	LVDS clock lane/TTL data lane serial pin

Interface	Pin Name	Direction	Description
eDP	EDP_TXiP(i=0~3)	O	eDP data lane positive output
	EDP_TXiN(i=0~3)	O	eDP data lane negative output
	EDP_DC_TP	O	eDP PHY DC test point
	EDP_AUXP	I/O	eDP CH-AUX positive differential output
	EDP_AUXN	I/O	eDP CH-AUX negative differential output
	EDP_R_BIAS	I	Let it floating
	EDP_OSC_CLK_24M	I	24MHz input reference clock
	edp_hotplug	I	eDP external hot plug signal
	edphdmi_cecinout	I/O	eDP HDMI CEC bus
	edphdmi2c_sda	I/O	eDP HDMI I2C data
	edphdmi2c_scl	I/O	eDP HDMI I2C clock

Interface	Pin Name	Direction	Description
HDMI	HDMI_TMDSDATANi(i=0~2)	O	HDMI negative TMDS differential line driver data output
	HDMI_TMDSDATAPi(i=0~2)	O	HDMI positive TMDS differential line driver data output
	HDMI_TMDSCLKN	O	HDMI negative TMDS differential line driver clock output
	HDMI_TMDSCLKP	O	HDMI positive TMDS differential line driver clock output
	HDMI_RESREF	I/O	HDMI reference resistor connection
	HDMI_HPD	I/O	HDMI hot plug detect signal
	HDMI_DDCCEC	I/O	HDMI ground reference for the hot plug detect signal

Interface	Pin Name	Direction	Description
MIPI	MIPI_TXRX_DATANi(i=0~3)	I/O	MIPI TXRX negative differential data line transceiver output
	MIPI_TXRX_DATAPi(i=0~3)	I/O	MIPI TXRX positive differential data line transceiver output
	MIPI_TXRX_CLKP	I/O	MIPI TXRX positive differential clock line transceiver output
	MIPI_TXRX_CLKN	I/O	MIPI TXRX negative differential clock line transceiver output
	MIPI_TXRX_REXT	I/O	MIPI TXRX external resistor connection
	MIPI_TX0_DATANi(i=0~3)	I/O	MIPI TX0 negative differential data line transceiver output
	MIPI_TX0_DATAPi(i=0~3)	I/O	MIPI TX0 positive differential data line transceiver output
	MIPI_TX0_CLKP	I/O	MIPI TX0 positive differential clock line transceiver output
	MIPI_TX0_CLKN	I/O	MIPI TX0 negative differential clock line transceiver output
	MIPI_TX0_REXT	I/O	MIPI TX0 external resistor connection
	MIPI_RX0_DATANi(i=0~3)	I/O	MIPI RX0 negative differential data line transceiver output
	MIPI_RX0_DATAPi(i=0~3)	I/O	MIPI RX0 positive differential data line transceiver output
	MIPI_RX0_CLKP	I/O	MIPI RX0 positive differential clock line transceiver output

Interface	Pin Name	Direction	Description
	MIPI_RX0_CLKN	I/O	MIPI RX0 negative differential clock line transceiver output
	MIPI_RX0_REXT	I/O	MIPI RX0 external resistor connection

2.9 IO Type

The following list shows IO type except DDR IO and all of Power/Ground IO.

Table 2-4 RK3288 IO Type List

Type	Diagram	Description	Pin Name
A		Analog IO Cell with IO voltage	EFUSE_VQPS
B		Dedicated Power supply to Internal Macro with IO voltage	SARADC_AIN[2:0]
C		Crystal Oscillator with high enable	XIN24M/XOUT24M
D		Tri-state output pad with input, which pullup/pulldown, slew rate and drive strength is configurable	Part of digital GPIO

Chapter 3 Electrical Specification

3.1 Absolute Maximum Ratings

Table 3-1 RK3288 absolute maximum ratings

Parameters	Related Power Group	Max	Unit
DC supply voltage for CPU	CPU_VDD,	1.5	V
DC supply voltage for Internal digital logic	LOGIC_VDD	1.5	V
DC supply voltage for GPU	GPU_VDD	1.5	V
DC supply voltage for PMU	PMU_VDD_1V0,	1.2	V
DC supply voltage for Analog part of USB	USB_AVDD_1V0	1.2	V
DC supply voltage for Digital GPIO (except for SAR-ADC, PLL, USB, DDR, MIPI PHY, LVDS, eDP, HDMI IO)	PMUIO_VDD APIO1_VDD APIO2_VDD APIO3_VDD APIO4_VDD APIO5_VDD LDCDC_VDD SDMMC0_VDD FLASH0_VDD FLASH1_VDD DVPIO_VDD	3.6	V
DC supply voltage for DDR IO	DDR0_VDD DDR1_VDD DDR0_VDDAO DDR1_VDDAO	1.65	V
DC supply voltage for Analog part of PLL	PLL_AVDD_1V0	1.2	V
DC supply voltage for Analog part of USB OTG/Host2.0	USB_AVDD_1V8 USB_AVDD_3V3	1.98 3.63	V
DC supply voltage for Analog part of USIC	USIC_AVDD_1V2	1.32	V
Analog Input voltage for SAR-ADC/TS-ADC	ADC_AVDD_1V8	1.98	V
DC supply voltage for Analog part of LVDS	LVDS_AVDD_1V0 LVDS_AVDD_1V8 LVDS_AVDD_3V3	1.2 1.98 3.6	V
DC supply voltage for Analog part of eDP	EDP_AVDD_1V0 EDP_AVDD_1V8	1.2 1.98	V
DC supply voltage for Analog part of HDMI	HDMI_AVDD_1V0 HDMI_AVDD_1V8	1.2 1.98	V
DC supply voltage for Analog part of MIPI PHY	MIPI_TX/RX_AVDD_1V8 MIPI_TX_AVDD_1V8 MIPI_RX_AVDD_1V8	1.98	V
Analog Input voltage for DP/DM/VBUS of USB OTG/Host2.0		5.0	V
Digital input voltage for input buffer of GPIO		3.6	V
Digital output voltage for output buffer of GPIO		3.6	V
Highest Storage Temperature	Tstg	125	°C
Lowest Storage Temperature	Tstg	-40	°C
Max Conjunction Temperature	Tj	125	°C

Absolute maximum ratings specify the values beyond which the device may be damaged permanently. Long-term exposure to absolute maximum ratings conditions may affect device reliability.

3.2 Recommended Operating Conditions

Table 1-6 describes the recommended operating condition for every clock domain.

Table 3-2 RK3288 recommended operating conditions

Parameters	Symbol ^①	Min	Typ	Max	Units
Internal CPU Power	CPU_VDD,	0.9	1.0	1.4	V
Internal digital logic Power	LOGIC_VDD,	0.9	1.0	1.35	V

Parameters	Symbol [®]	Min	Typ	Max	Units
Internal GPU Power	GPU_VDD,	0.9	1.0	1.35	V
Internal digital logic Power	PMU_VDD_1V0	0.9	1.0	1.1	V
Digital GPIO Power(3.3V/2.5V/1.8V)	PMUIO_VDD APIO1_VDD APIO2_VDD APIO3_VDD APIO4_VDD APIO5_VDD LCDC_VDD SDMMC0_VDD FLASH0_VDD FLASH1_VDD DVPIO_VDD	3.0 2.25 1.62	3.3 2.5 1.8	3.6 2.75 1.98	V
DDR IO (DDR3 mode) Power	DDR0_VDD DDR1_VDD DDR0_VDDAO DDR1_VDDAO	1.425	1.5	1.575	V
DDR IO (DDR3L mode) Power	DDR0_VDD DDR1_VDD DDR0_VDDAO DDR1_VDDAO	1.283	1.35	1.45	V
DDR IO (LPDDR2/LPDDR3 mode) Power	DDR0_VDD DDR1_VDD DDR0_VDDAO DDR1_VDDAO	1.14	1.2	1.3	V
DDR reference supply (VREF) Input	VREF	0.49* DDR_VDD	0.5* DDR_VDD	0.51*DDR_VDD	V
DDR External termination voltage		VREF- 40mV	VREF	VREF+ 40mV	V
PLL Analog Power	PLL_AVDD_1V0	0.9	1.0	1.1	V
SAR-ADC/TSADC Analog Power	ADC_AVDD_1V8	1.62	1.8	1.98	V
USB OTG/Host2.0 Digital Power	USB_AVDD_1V0	0.9	1.0	1.1	V
USB OTG/Host2.0 Analog Power(1.8V)	USB_AVDD_1V8	1.62	1.8	1.98	V
USB OTG/Host2.0 Analog Power(3.3V)	USB_AVDD_3V3	3.0	3.3	3.6	V
USB OTG/Host2.0 external resistor	REXT	NA	200	NA	Ohm
USIC Analog Power	USIC_AVDD_1V2	1.0	1.2	1.32	V
LVDS Analog Power(1.0V)	LVDS_AVDD_1V0	0.9	1.0	1.1	V
LVDS Analog Power(1.8V)	LVDS_AVDD_1V8	1.62	1.8	1.98	V
LVDS Analog Power(3.3V)	LVDS_AVDD_3V3	3.0	3.3	3.6	V
eDP Analog Power(1.0V)	EDP_AVDD_1V0	0.9	1.0	1.1	V
eDP Analog Power(1.8V)	EDP_AVDD_1V8	1.62	1.8	1.98	V
HDMI Analog Power(1.0V)	HDMI_AVDD_1V0	0.9	1.0	1.1	V
HDMI Analog Power(1.8V)	HDMI_AVDD_1V8	1.62	1.8	1.98	V
MIPI PHY Analog Power	MIPI_TXRX_AVDD_1V8 MIPI_TX_AVDD_1V8 MIPI_RX_AVDD_1V8	1.62	1.8	1.98	V
PLL input clock frequency		N/A	24	N/A	MHz
SDIO IO frequency		N/A	N/A	150	MHz
Max CPU frequency 0°C~80°C	RK3288	N/A	N/A	1.6	GHz
	RK3288 W version	N/A	N/A	1.6	GHz
	RK3288-D	N/A	N/A	1.6	GHz
	RK3288-CG	N/A	N/A	1.8	GHz
	RK3288-CG W Version	N/A	N/A	1.8	GHz
	RK3288-C	N/A	N/A	1.8	GHz
	RK3288K	N/A	N/A	1.8	GHz
Max CPU frequency [®] -20°C~0°C and 80°C~85°C	RK3288K	N/A	N/A	1.6	GHz

Parameters	Symbol ^①	Min	Typ	Max	Units
Max GPU frequency 0℃~80℃	RK3288	N/A	N/A	500	MHz
	RK3288 W version	N/A	N/A	500	MHz
	RK3288-D	N/A	N/A	500	MHz
	RK3288-CG	N/A	N/A	600	MHz
	RK3288-CG W Version	N/A	N/A	600	MHz
	RK3288-C	N/A	N/A	600	MHz
	RK3288K	N/A	N/A	600	MHz
Max GPU frequency ^② -20℃~0℃and 80℃~85℃	RK3288K	N/A	N/A	500	MHz
Ambient Operating Temperature for RK3288, RK3288 W Version, RK3288-C, RK3288-CG, RK3288-CG W Version, RK3288-D,	Ta	0	25	80	℃
Ambient Operating Temperature for RK3288K	Ta	-20	25	85	℃

Notes :

- ① Symbol name is same as the pin name in the io descriptions
- ② The max frequency is affected by the heat emission condition and the temperature control system.

3.3 DC Characteristics

Table 3-3 RK3288 DC Characteristics

Parameters	Symbol	Min	Typ	Max	Units	
Digital GPIO @3.3V	Input Low Voltage	Vil	-0.3	0	3.3x0.3	V
	Input High Voltage	Vih	3.3x0.7	3.3	3.3+0.3	V
	Output Low Voltage	Vol	-0.3	NA	NA	V
	Output High Voltage	Voh	NA	NA	3.6	V
	Pullup Resistor	Rpu	33.7	58	101.5	Kohm
	Pulldown Resistor	Rpd	34.2	60.1	109.3	Kohm
Digital GPIO @1.8V	Input Low Voltage	Vil	-0.3	0	1.8x0.3	V
	Input High Voltage	Vih	1.8x0.7	1.8	1.8 + 0.3	V
	Output Low Voltage	Vol	-0.3	NA	NA	V
	Output High Voltage	Voh	NA	NA	1.8+0.3	V
	Pullup Resistor	Rpu	35	62.9	120	Kohm
	Pulldown Resistor	Rpd	35.1	61	113.9	Kohm
DDR IO @DDR3 mode	Input High Voltage	Vih_dds	VREF + 0.09	NA	MVDD	V
	Input Low Voltage	Vil_dds	-0.3	0	VREF - 0.09	V
	Output High Voltage	Voh_dds	0.8xMVDD	NA	N/A	V
	Output Low Voltage	Vol_dds	N/A	NA	0.2*MVDD	V
	Input termination resistance(ODT) to VDDIO_DDRi/2 (i=0~6)	Rtt	100 54 36	120 60 40	140 66 44	Ohm
DDR IO @DDR3L mode	Input High Voltage	Vih_dds	VREF + 0.09	NA	MVDD	V
	Input Low Voltage	Vil_dds	-0.3	0	VREF - 0.09	V
	Output High Voltage	Voh_dds	0.8xMVDD	NA	N/A	V
	Output Low Voltage	Vol_dds	N/A	NA	0.2*MVDD	V
	Input termination resistance(ODT) to VDDIO_DDRi/2 (i=0~6)	Rtt	100 54 36	120 60 40	140 66 44	Ohm
DDR IO @LPDDR2/ LPDDR3 mode	Input High Voltage	Vih_dds	VREF + 0.13	NA	MVDD	V
	Input Low Voltage	Vil_dds	-0.3	NA	VREF - 0.13	V
	Output High Voltage	Voh_dds	0.9*VREF	NA	NA	V

Parameters		Symbol	Min	Typ	Max	Units
	Output Low Voltage	Vol_dds	NA	NA	0.1*VREF	V
LVDS IO @LVDS mode	Output High Voltage	Voh	NA	NA	1060	mV
	Output Low Voltage	Vol	660	NA	NA	mV
	Output differential voltage	Vod	202	NA	354	mV
	Output offset voltage	Vos	885	NA	915	mV
	Output impedance, single ended	Ro	40	NA	140	Ω
	Ro mismatch between A & B	ΔRo	NA	NA	10	%
	Change in Vod between 0 and 1	ΔVod	NA	NA	25	mV
	Change in Vod between 0 and 1	ΔVos	NA	NA	25	mV
	LVDS IO @TTL mode	Output High Voltage	Voh	3	3.3	NA
Output Low Voltage		Vol	NA	0	0.2	V
Input High Current		Iih	NA	±1	±10	uA
Input Low Current		Iil	NA	±1	±10	uA
Short-Circuit Output Current		Ios	NA	35	60	mA
Output impedance		Ro	40	NA	460	Ω
Device active current		Icc	17	20	23	mA/lane
HDMI	Single-ended standby voltage	Voff	avddtmds±10			mV
	Single-ended output swing voltage RT=50Ω	Vswing	400	NA	600	mV
		Vswing_data	400	NA	600	mV
		Vswing_clock	200	NA	600	mV
	Single-ended output high voltage	Vh	avddtmds±10			mV
			avddtmds-200	NA	avddtmds+10	mV
		Vh_data	avddtmds-400	NA	avddtmds+10	mV
	Single-ended output low voltage	Vl	avddtmds-600	NA	avddtmds-400	mV
			avddtmds-700	NA	avddtmds-400	mV
		VI_data	avddtmds-1000	NA	avddtmds-400	mV
		VI_clock	avddtmds-1000	NA	avddtmds-200	mV
Differential source termination load	Rterm	50	NA	200	Ω	
MIPI PHY	Input signal voltage range	Vi	-50	NA	1350	mV
	Input leakage current	Ileak	-10	NA	10	uA
	Ground	Vgndsh	-50	NA	50	mV
	Maximum transient output voltage level	Voh(absmax)	-0.15	NA	1.45	V
	Maximum transient time above Voh(absmax)	tVoh(absmax)	NA	NA	20	ns
	HS transmit differential output voltage magnitude	Vod	140	200	270	mV
	Change in differential output voltage magnitude between logic states	Δ Vod	NA	NA	14	mV
	Steady-state common-mode output voltage	Vcmtx	150	200	250	mV
	Change in steady-state common-mode output voltage between logic states	ΔVcmtx(1,0)	NA	NA	5	mV
	HS output high voltage	Vohhs	NA	NA	360	mV
	Single-ended output impedance	Zos	40	50	62.5	Ω
	Single-ended output impedance mismatch	ΔZos	NA	NA	10	Ω
	Output low-level SE output	Vol	-50	NA	50	mV
	Output high-level SE output	Voh	1.1	1.2	1.3	V
	Single-ended output impedance	Zolp	110	NA	NA	Ω
	Single-ended output impedance mismatch driving opposite level	ΔZolp(01,10)	NA	NA	20	%
	Single-ended output impedance mismatch driving same level	ΔZolp(00,11)	NA	NA	5	%

Parameters	Symbol	Min	Typ	Max	Units
Differential input high voltage threshold	Vidth	NA	NA	70	mV
Differential input low voltage threshold	Vidtl	-70	NA	NA	mV
Single ended input high voltage	Vihhs	NA	NA	460	mV
Single ended input low voltage	Vilhs	-40	NA	NA	mV
Input common mode voltage	Vcmrxdc	70	NA	330	mV
Differential input impedance	Zid	80	NA	125	Ω
Input low voltage	Vil	NA	NA	550	mV
Input high voltage	Vih	880	NA	NA	mV
Input hysteresis	Vhyst	25	NA	NA	mV
Input low fault threshold	Vilf	NA	NA	200	mV
Input high fault threshold	Vihf	450	NA	NA	mV

3.4 Electrical Characteristics for General IO

Table 3-4 RK3288 Electrical Characteristics for Digital General IO

Parameters	Symbol	Test condition	Min	Typ	Max	Units	
Digital GPIO @3.3V	Input leakage current	Ii	Vin = 3.3V or 0V	NA	NA	10	uA
	Tri-state output leakage current	Ioz	Vout = 3.3V or 0V	NA	NA	10	uA
	High level input current	Iih	Vin = 3.3V, pulldown disabled	NA	NA	10	uA
			Vin = 3.3V, pulldown enabled	NA	NA	106.4	uA
	Low level input current	Iil	Vin = 0V, pullup disabled	NA	NA	10	uA
			Vin = 0V, pullup enabled	NA	NA	107.8	uA
Digital GPIO @1.8V	Input leakage current	Ii	Vin = 1.8V or 0V	NA	NA	10	uA
	Tri-state output leakage current	Ioz	Vout = 1.8V or 0V	NA	NA	10	uA
	High level input current	Iih	Vin = 1.8V, pulldown disabled	NA	NA	10	uA
			Vin = 1.8V, pulldown enabled	NA	NA	61.3	uA
	Low level input current	Iil	Vin = 0V, pullup disabled	NA	NA	10	uA
			Vin = 0V, pullup enabled	NA	NA	61.4	uA

3.5 Electrical Characteristics for PLL

Table 3-5 RK3288 Electrical Characteristics for PLL

Parameters	Symbol	Test condition	Min	Typ	Max	Units	
PLL	Divided reference frequency range	Fin	0.269	NA	2200	MHz	
	output frequency range	Fout	0.440	N/A	2200	MHz	
	Lock time	Tlt	N/A	NA	500	Cycles of divided reference clock	
	Power consumption (normal mode)	N/A	N/A	3	N/A	mW	
	Period jitter (P-P)	N/A	N/A	N/A	NA	+/-2.5	%
	Junction temperature	N/A			70	125	°C

3.6 Electrical Characteristics for SAR-ADC

Table 3-6 RK3288 Electrical Characteristics for SAR-ADC

Parameters	Symbol	Test condition	Min	Typ	Max	Units
ADC resolution			N/A	10	N/A	bits
Conversion speed	Fs	The duty cycle should be between 40%~60%	NA	N/A	1	MSPS
Differential Non Linearity	DNL		N/A	±1	N/A	LSB
Integral Non Linearity	INL		N/A	±2	N/A	LSB
Gain Error	Egain		-8	N/A	8	LSB
Offset Error	Eoffset		-8	N/A	8	mV
Analog Supply Current(VDDA_SARADC)			N/A	200	N/A	uA
Digital Supply Current			N/A	50	N/A	uA
Power Down Current from AVDD			NA	0.5	NA	uA
Power Down Current from DVDD			N/A	1	N/A	uA
Power up time			N/A	7	N/A	1/Fs

3.7 Electrical Characteristics for TSADC

Table 3-7 RK3288 Electrical Characteristics for TSADC

Parameters	Symbol	Test condition	Min	Typ	Max	Units
ADC resolution			N/A	12	N/A	bits
TSADC Accuracy	Fs		NA	N/A	+/-5	°C
Active power			N/A	0.4	N/A	mW
Clock Frequency	Fclk		NA	NA	50	KHz
Power Down Current from AVDD			NA	1	NA	uA
Power Down Current from DVDD			N/A	2	N/A	uA
Power up time			N/A	7	N/A	1/Fs

3.8 Electrical Characteristics for USB Interface

Table 3-8 RK3288 Electrical Characteristics for USB Interface

Parameters	Symbol	Test condition	Min	Typ	Max	Units
HS transmit, maximum transition density (all 0's data in DP/DM)	Current From OTG_DVDD	55°C ,USBVDD_1V0 = 1.0V USBVDD_1V8=1.8V USBVDD_3V3=3.3V, 15-cm USB cable attached to DP/DM	N/A	6.151	N/A	mA
	Current From OTG_VDD33		N/A	4.97	N/A	mA
	Current From OTG_VDD18		N/A	18.5	N/A	mA
HS transmit, minimum transition density (all 1's data in DP/DM)	Current From OTG_DVDD		N/A	5.521	N/A	mA
	Current From OTG_VDD33		N/A	3.63	N/A	mA
	Current From OTG_VDD18		N/A	15.5	N/A	mA
HS idle mode	Current From OTG_DVDD		N/A	5.841	N/A	mA
	Current From OTG_VDD33		N/A	3.19	N/A	mA
	Current From OTG_VDD18		N/A	6.58	N/A	mA
FS transmit, maximum transition density (all 0's data in DP/DM)	Current From OTG_DVDD		N/A	4.251	N/A	mA
	Current From OTG_VDD33	N/A	11.81	N/A	mA	

Parameters		Symbol	Test condition	Min	Typ	Max	Units
DP/DM)	Current From OTG_VDD18			N/A	6.56	N/A	mA
	Current From OTG_DVDD			N/A	5.171	N/A	mA
LS transmit, maximum transition density (all 0's data in DP/DM)	Current From OTG_VDD33			N/A	12.81	N/A	mA
	Current From OTG_VDD18			N/A	6.61	N/A	mA
	Current From OTG_DVDD			N/A	53.4	N/A	uA
Suspend mode	Current From OTG_VDD33			N/A	1.1	N/A	uA
	Current From OTG_VDD18			N/A	6.6	N/A	uA
	Current From OTG_DVDD			N/A	0.113	N/A	mA
Sleep mode	Current From OTG_VDD33			N/A	0.1	N/A	uA
	Current From OTG_VDD18			N/A	0.004	N/A	mA
	Current From OTG_DVDD			N/A		N/A	

3.9 Electrical Characteristics for USIC Interface

Table 3-9 RK3288 Electrical Characteristics for USIC Interface

Parameters		Symbol	Test condition	Min	Typ	Max	Units
HS transmit, maximum transition density	Current From DVDD		55°C , VDD12 = 1.2V, DVDD = 1.0V , 12MHz reference clock 10pF load on STROBE	N/A	3.26	N/A	mA
	Current From VDD12			N/A	10.20	N/A	mA
HS transmit, minimum transition density	Current From DVDD			N/A	3.05	N/A	mA
	Current From VDD12			N/A	8.28	N/A	mA
HS idle mode	Current From DVDD			N/A	2.71	N/A	mA
	Current From VDD12			N/A	0.001	N/A	mA
HS Receive	Current From DVDD			N/A	3.07	N/A	mA
	Current From VDD12			N/A	1.58	N/A	mA
Suspend mode	Current From DVDD			N/A	0.012	N/A	mA
	Current From VDD12			N/A	0.3	N/A	uA
Sleep mode	Current From DVDD		N/A	0.049	N/A	mA	
	Current From VDD12		N/A	0.6	N/A	uA	

3.10 Electrical Characteristics for DDR IO

Table 3-10 RK3288 Electrical Characteristics for DDR IO

Parameters		Symbol	Test condition	Min	Typ	Max	Units
DDR IO @DDR3 mode	VDDIO_DDR standby current, ODT OFF		@ 1.5V , 125°C	NA	0.01	2.11	uA
	Input leakage current, SSTL mode, unterminated		@ 1.5V , 125°C	NA	0	0.53	uA
DDR IO @DDR3L mode	Input leakage current		@ 1.35V , 125°C	NA	0.01	2.01	nA
	VDD(1.2V) quiescent current		@ 1.35V , 125°C	NA	0	0.51	uA
DDR IO @LPDDR2/LPDDR3 mode	Input leakage current		@ 1.2V , 125°C	NA	0	0.49	nA
	VDD(1.2V) quiescent current		@ 1.2V , 125°C	NA	0	1.89	uA

3.11 Electrical Characteristics for eFuse

Table 3-11 RK3288 Electrical Characteristics for eFuse

Parameters		Symbol	Test condition	Min	Typ	Max	Units
Active mode	VDD current in Read mode	Iread_vdd	normal read	15	20	30	mA

	Parameters	Symbol	Test condition	Min	Typ	Max	Units
	VDD current in PGM mode	Ipgm_vdd	STROBE high	0.5	1	2.5	mA
	VQPS current in PGM mode	Ipgm_vqps	STROBE high	5	10	15	mA
standby mode	VDD current in standby mode	Istandby_vdd	Standby	0.2	0.5	2	mA

3.12 Electrical Characteristics for HDMI

Table 3-12 RK3288 Electrical Characteristics for HDMI

Parameters	Symbol	Test condition	Min	Typ	Max	Units
Differential output signal rise time	tR	20~80% RL=50Ω	75	NA	0.4UI	ps
	tR_DATA	20~80% RL=50Ω	42.5	NA	NA	ps
	tR_CLOCK	20~80% RL=50Ω	75	NA	NA	ps
Differential output signal fall time	tF	20~80% RL=50Ω	75	NA	NA	ps
	tF_DATA	20~80% RL=50Ω	42.5	NA	NA	ps
	tF_CLOCK	20~80% RL=50Ω	75	NA	NA	ps

3.13 Electrical Characteristics for MIPI PHY

Table 3-13 RK3288 Electrical Characteristics for MIPI PHY

Parameters	Symbol	Test condition	Min	Typ	Max	Units
HS Transmitter AC specifications						
Common-mode variations above 450 MHz	ΔVCMTX(HF)	80Ω≤RL≤125Ω	NA	NA	15	mVrms
Common-mode variations between 50MHz - 450MHz	ΔVCMTX(LF)	80Ω≤RL≤125Ω	NA	NA	25	mVp
Differential output signal rise time	tr	20% to 80%, RL=50Ω	100	NA	NA	ps
Differential output signal fall time	tf	20% to 80%, RL=50Ω	100	NA	NA	ps
LS Transmitter AC specifications						
Single ended output rise/fall time	trlp, tflp	15% to 85%, CL < 70pF	NA	NA	25	ns
	treop	30% to 85%, CL < 70pF	NA	NA	35	ns
Signal slew rate		15% to 85%, CL < 70pF	NA	NA	150	mV/ns
Load capacitance	CL		0	NA	70	pF
HS Receiver AC specifications						
Common mode interference beyone 450MHz	ΔVCMRX(HF)		NA	NA	200	mVpp
Common mode interference between 50MHz and 450MHz	ΔVCMRX(LF)		-50	NA	50	mVpp
Common-mode termination amplitude	CCM		NA	NA	60	pF
LP Receiver AC Specifications						
Input pulse rejection	eSPIKE		NA	NA	300	V.ps
Minimum pulse response	TMIN		20	NA	NA	ns
Pk-to-Pk interference voltage	VINT		NA	NA	400	mVpp
interference frequency	fINT		450	NA	NA	MHz

3.14 Electrical Characteristics for LVDS

Table 3-14 RK3288 Electrical Characteristics for LVDS

	Parameters	Symbol	Test condition	Min	Typ	Max	Units
LVDS mode	Clock signal duty cycle	clock	1.2GHz	45	NA	30	%
	Vod fall time, 20~80%	t _{fall}	R _{load} =100Ω±1%	100	NA	250	ps
	Vod rise time, 20~80%	t _{rise}	R _{load} =100Ω±1%	100	NA	250	ps
	t _{PHLA} -t _{PLHB} or t _{PHLB} -t _{PLHA} , differential skew	tskew1	Any differential pair on package	NA	NA	30	ps
	t _{pdiff} [m]-t _{pdiff} [n] Channel to channel skew	tskew2	Any two signal on package	NA	NA	50	ps
TTL mode	Maximum data rate		CL=10pF, RL=300kΩ	NA	200	NA	Mbit/s
	TRLP/TFLP		DOUT at RL=300kΩ to GND	1	1.5	2	ns
	Pulse skew	tsk	CL=1-10pF, RL=30kΩ	NA	10	NA	ns
	Slew rate, transition region	SR	V _{cc} =3.3V, CL=10pF	NA	27	NA	V/ns

Chapter 4 Thermal Management

4.1 Overview

For reliability and operability concerns, the absolute maximum junction temperature of RK3288 has to be below 125°C

4.2 Package Thermal Characteristics

Table 4-1 provides the thermal resistance characteristics for the package used on RK3288. The resulting simulation data for reference only, please prevail in kind test.

Table 4-1 RK3288 Thermal Resistance Characteristics

Package (FCBGA636LD)	θ_{JA} (°C/W)	θ_{JB} (°C/W)	θ_{JC} (°C/W)
RK3288	16.1	8.7	0.4

Note: The testing PCB is base on 4 layers(2S2P), 4 inch x 4.5 inch, 1.6 mm Thickness, Ambient temperature is 25 ° C.